

AEROSPACE EUROPE BULLETIN

CEAS-AIDAA CONFERENCE 2025

Innovation, Collaboration, and Global Engagement
at the CEAS-AIDAA Conference 2025

- Interview with Assoc. Prof. S.W. Rienstra on Aeroacoustics
- 'Be Seen and Be Aware' - Preventing Mid-Air Collisions in General Aviation
- How Sector-Agnostic Regulations Affect the European Space Supply Chain
- Product Assurance: the Silent Force Behind Copernicus Mission Success





The Council of European Aerospace Societies (CEAS) is an International Non-Profit Organisation, with the aim to develop a framework within which the major European Aerospace Societies can work together.

It was established as a legal entity conferred under Belgium Law on 1st of January 2007. The creation of this Council was the result of a slow evolution of the 'Confederation' of European Aerospace Societies which was born fifteen years earlier, in 1992, with three nations only at that time: France, Germany and the UK.

IT CURRENTLY COMPRISES:

- **11 Full Member Societies:** Czech Republic (CzAeS) – France (3AF) – Germany (DGLR) – Italy (AIDAA) – The Netherlands (NVvL) – Poland (PSAA) – Romania (AAAR) – Spain (AIAE) – Sweden (FTF) – Switzerland (SVFW) – United Kingdom (RAeS);
- **7 Corporate Members:** ESA, EASA, EUROCONTROL, EUROAVIA, INCAS, SAE International, Von Karman Institute;
- **10 Societies having signed a Memorandum of Understanding (MoU) with CEAS:** AAE (Air and Space Academy), AIAA (American Institute of Aeronautics and Astronautics), CSA (Chinese Society of Astronautics), EASN (European Aeronautics Science Network), EREA (European association of Research Establishments in Aeronautics), ICAS (International Council of Aeronautical Sciences), KSAS (Korean Society for Aeronautical and Space Sciences), PEGASUS (Partnership of a European Group of Aeronautics and Space Universities), Society of Flight Test Engineers (SFTE-EC) and Women in Aerospace Europe.

CEAS is governed by a Board of Trustees, with representatives of each of the Member Societies. Its Head Office is located in Belgium: c/o DLR – Rue du Trône 98 – 1050 Brussels. www.ceas.org

WHAT DOES CEAS OFFER YOU ?

Knowledge Transfer:

- A structure for Technical Committees

High-Level European Conferences:

- Technical pan-European events dealing with specific disciplines
- The biennial AEROSPACE EUROPE Conference

Publications:

- CEAS Aeronautical Journal
- CEAS Space Journal
- AEROSPACE EUROPE Bulletin

Technical Committees organising Specialist Conferences:

- AIAA/CEAS Aeroacoustics conference
- ERF European Rotorcraft Forum
- HISST International Conference on High-Speed Vehicle Science and Technology
- CEAS EuroGNC Guidance, Navigation & Control
- IFASD International Forum on Aeroelasticity and Structural Dynamics

Honours and Awards:

- Annual CEAS Gold Medal
- Medals in Technical Areas
- Distinguished Service Award

Online platforms:

- European Aerospace Repository
- European Aerospace Intranet

AEROSPACE EUROPE Bulletin

The AEROSPACE EUROPE Bulletin is a quarterly bulletin that aims to provide in depth information about the progress of European aerospace from every perspective.

We always welcome contributions from other parties such as decisions makers, scientist, engineers and students.

Write us at bulletin@ceas.org

EDITOR: CEAS

Director of the Publication: Cornelia Hillenherms

Editorial Committee

Editor-in Chief: Thomas Vermin
Aerospace.europe.editor@ceas.org

Committee's Members: Andrea Alaimo, Jonathan Cooper, Franco Bernelli, Anastasia Pesce, Anastasia Pesce, Thomas Vermin.

Art Direction & Design: Sophie Bougnon
sophie.bougnon1@sfr.fr / www.sbgraphisme.com

**THE OFFICERS
OF THE BOARD IN 2026:**

CEAS President:

Cornelia Hillenherms /
cornelia.hillenherms@dglr.de

Vice-President, Finance:

Philip Nickenig / philip.nickenig@dglr.de

**Vice-President, Publications
and External Relations:**

Lukasz Kiskowskiak /
lukasz.kiskowskiak@wat.edu.pl

Vice-President, Awards

and Membership: Petter Krus

Director General: Andrea Alaimo /
andrea.alaimo@unikore.it

Secretary: Beata Wierzbinska-Prus /
beata.prus@pw.edu.pl

Chair of the Aeronautics Branch:

Jonathan Cooper /
j.e.cooper@bristol.ac.uk

Chair of the Space Branch:

Anastasia Pesce /
anastasia.pesce@esa.int

CEAS Trustee: Daniel Reckzeh /
daniel.reckzeh@dglr.de

CEAS Trustee and Vice-President

Finance: Philip Nickenig

Point of contact: Birgit Neuland /
birgit.neuland@dglr.de

T: +49 228 30 80 50

 **Italy – AIDAA**

Casella Postale 227 -

I-00187 Roma V.R. - www.aidaa.it

President: Sergio De Rosa /
sergio.derosa@unina.it

CEAS Trustees: Erasmo Carrera
Carlo Bettanini

carlo.bettanini@unipd.it

Point of contact: Daniela Vinazza /
daniela@aidaa.it

T: +39 366 144 21 31

 **Netherlands (The) – NVvL**

c/o Netherlands Aerospace Centre
Anthony Fokkerweg 2

NL- 1059 CM Amsterdam

www.nvvl.eu

President: Mark van Venrooij /
mark.van.venrooij@nlr.nl

CEAS Trustees: Mark Van Venrooij,
Fred Abbink / fj.abbink@planet.nl

Point of contact: Regina Sluitjer /
nvvl@nlr.nl - T: +31 88 511 3113

 **Poland – PSAA**

Nowowiejska 24 - 00-665 Warsaw
www.psa.meil.pw.edu.pl

President:

Tomasz Goetzendorf-Grabowski /
tomasz.grabowski@pw.edu.pl

CEAS Trustees:

Tomasz Goetzendorf-Grabowski
Lukasz Kiskowskiak /

lukasz.kiskowskiak@wat.edu.pl

Point of contact:

Beata Wierzbinska-Prus /
beata.prus@pw.edu.pl

T: +48 22 234 54 28

 **Romania – AAAR**

c/o COMOTI

Bd Luliu Maniu 220D
061126 Bucharest, Sector 6 -

Romania C.P. 174, O.P. 76

www.aaar.ro - www.comoti.ro

President: Valentin Silivestru /
valentin.silivestru@comoti.ro

CEAS Trustees: Radu Mihalache /
radu.mihalache@comoti.ro

Ion Fuiorea / ifuiorea@yahoo.com

Point of contact: Valentin Silvestru
T : + 4 021 434 02 40

 **Spain – AIAE**

Francisco Silvela 71,
Entrepantana - 28028 Madrid

www.coiae.es

President: José Manuel Hesse Martin /
jmhesse@coiae.es

CEAS Trustees: José Manuel Hesse
Martin, Arturo de Vicente /

arturodvh@coiae.es

Point of contact: Santiago Carmona /
info@coiae.es - T : + 34 91 745 30 30

 **Sweden – FTF**

c/o SSC, PO Box 4207

SE-17154 SOLNA

www.ftfsweden.se

President: Roland Karlsson /
rkrolandk@gmail.com

CEAS Trustees: Svjetlana Stekovic /
svjetlana.stekovic@liu.se

Petter Krus / petter.krus@liu.se

Point of contact: Björn Jonsson /
bjorn.jonsson@fmv.se

T: + 46 70-782 62 61

 **Switzerland – SVFW**

Laerchenstrasse 1 CH-5737

Menziken - www.svfw.ch

President : Jürg Wildi /
juerg.wildi@bluewin.ch

CEAS Trustees: Jürg Wildi

Georges Bridel /

georges.bridel@alr-aerospace.ch

Point of contact: Mirjam Hauser /
mirjam.hauser@icloud.com

T: + 41 44 632 11 11

 **United Kingdom – RAeS**

No.4 Hamilton Place - London

W1J 7 BQ - www.aerosociety.com

President: Alisdair Wood FRAeS

CEAS Trustees: Emma Bossom MRAeS
/ emma.bossom@aerosociety.com

Jonathan Cooper CEng FRAeS /
j.e.cooper@bristol.ac.uk

Point of contact: Emma Bossom
T: +44 (0) 20 7670 4332

Full members:

 **Czech Republic – CzAeS**

Novotneho Lavka 5 - 110 00 Prague
www.csvts.cz

President: Daniel Hanus /
hanus@csvts.cz

CEAS Trustees:

Daniel Hanus,

Jan Rohac / xrohac@fel.cvut.cz

Point of contact:

Daniel Hanus : + 420 221 082 295

 **France – 3AF**

6,rue Galilée - F-75016 Paris

www.3af.fr

President: Bruno Berthet

CEAS Trustees: Louis Le Portz

Bruno Berthet /

bruno.berthet@rafaut.fr

Point of contact: Clara Lasserre /
clara.lasserre@3af.fr

T : +33 1 56 64 12 31

 **Germany – DGLR**

Godesberger Allee 70 -

D- 53175 Bonn - www.dglr.de

President: Roland Gerhards /

roland.gerhards@dglr.de

CEAS President: Cornelia Hillenherms

Corporate members:

• EASA

Konrad - Adenauer - Ufer 3
D-50542 Cologne (Germany)
www.easa.europa.eu

CEAS Representative:

David Solar

• ESA

24, rue du Général Bertrand -
75345 Paris Cedex 7
www.esa.int

CEAS Space Branch Members

Anastasia Pesce /
anastasia.pesce@esa.int
Johan Steelant /
johan.steelant@esa.int

• EUROAVIA

Kluyverweg 1 - 2629 HS, Delft, NL
www.euroavia.eu

President: Pedro Moreira /
pedro.moreira@euroavia.eu

CEAS Representative:

Leo Buchner

• EUROCONTROL

Rue de la Fusée 96 - Brussels 1130
<https://www.eurocontrol.int/>

CEAS Representative: Mr Eric Hoffmann, Mr Guisepppe Murgese

• **INCAS** - National Institute for
Aerospace Research "Elie Carafoli"
220 Iuliu Maniu Blvd., Sector 6,
061126, Bucharest, Romania
<https://www.incas.ro/>

CEAS representative: Adriana Stefan
Email: incas@incas.ro

• SAE International

Address: Fred. Roeskestraat 115, 1076
EE Amsterdam, The Netherlands
<https://www.sae.org>

CEAS Representative: John Tintinalli

CEAS Representative:

Jacob Bangsgaard

• Von Karman Institute

72, chaussée de Waterloo
1640 Rhode-St-Genèse, Belgium
<https://www.vki.ac.be>

CEAS Repres.: Christophe Schram
christophe.schram@vki.ac.be

Societies having signed an MOU with ceas:

• Académie de l'Air et de l'Espace (AAE)

1, avenue Camille Flammarion -
F-31500 Toulouse
www.academieairespace.com

• American Institute of Aeronautics and Astronautics (AIAA)

12700 Sunrise Valley Drive
Suite 200, Reston
VA 20191 - 5807 USA
www.aiaa.org

• Chinese Society of Astronautics (CSA)

CSA Zhang yao - WANG Yiran,
n° 8, Fucheng Road, Haidian district
P.O. Box 838
100 830 Beijing, China
wangyr@spacechina.com
www.csaspace.org.cn/

• European Aerospace Science Network (EASN)

EASN - Rue du Trône 98 -
1050 Brussels, Belgium
<https://www.easn.net>

Chairman: Andreas Strohmayer
(University of Stuttgart)

Vice Chairman: Konstantinos
Tserpes (University of Patras)
kitserpes@upatras.gr

• Association of European Research Establishments in Aeronautics (EREA)

Chairman of EREA:
Prof. Antonio Blandini (CIRA)
Acting Chair:

Dr. Markus Fischer (DLR)
Chair of Executive Secretariat:
Ms. Claudia Dobre (INCAS)
<https://www.erea.org>

• International Council of the Aeronautical Sciences (ICAS)

President: Chris Atkins
Executive Secretary: Axel Probst
c/o DGLR - Godesberger Allee
70 - D- 53175 Bonn
icas@icas.org - www.icas.org

• Korean Society for Aeronautical and Space Sciences (KSAS)

Room 1001, 635-4 - Yeogdam-Dong
- 135-703 Gangnam - Gu Republic of
Korea - ksas@ksass.or.kr
<https://www.ksas.or.kr>

• Partnership of a European Group of Aeronautics and Space Universities (PEGASUS)

Chair: Emmanuel Zenou
emmanuel.zenou@isae-superaero.fr
www.pegasus-europe.org

• Society of Flight Test Engineers (SFTE-EC)

www.sfte-ec.org/

Six Societies in European Aerospace science and Technology Research closely linked with CEAS (Ecaero-2):

• EASN: European Aerospace Science Network



Vice Chairman: Konstantinos
Tserpes - University of Patras
kitserpes@upatras.gr

• ECCOMAS: European Community on Computational Methods in Applied Sciences



Campus Nord UPC - Building C3
"Zona Comercial" - Jordi Girona, 1-3
(08034) - Barcelona (Spain)
www.eccomas.org/
eccomas@cimne.upc.edu

President: Ferdinando Auricchio
auricchio@unipv.it

• ERCOFTAC: European Research Community on Flow Turbulence And Combustion



<https://www.ercoftac.org/>

Chair of Executive Committee:

Prof. Dominic Von Terzi
admin@cado-ercoftac.com

• EUCASS: European Conference for Aero-Space Sciences



www.eucass.eu

EUCASS President:

Christophe Bonnal
christophe.bonnal@maia-space.com

• EUROMECH: European Mechanics Society



<https://euromech.org>

President: Professor Roberto Verzicco / roberto.verzicco@uniroma2.it

• EUROTURBO: European Turbomachinery Society



<https://www.euroturbo.eu>

Chairman: Raul Vasquez Diaz
Raul.Vasquez@Rolls-Royce.com

Contents

CEAS PRESENTATION

- Members and Partners 2
- Editorial 5
- CEAS President's Report for year 2025 6
- Innovation, Collaboration, and Global Engagement at the CEAS-AIDAA Conference 2025 10
- CEAS/EASN Statement on the EU's Framework Programme for Research and Innovation (FP10) 13

PERSONALITY INTERVIEW

- Assoc. Prof. Dr S.W. Rienstra, expert in Aeroacoustics and former chairman of the Aeroacoustics committee 14

AERONAUTICS TECHNOLOGY

- Be seen and be aware – Preventing Mid-Air Collisions in General Aviation 18
- FASTet: Developing Data-Driven Solutions for Air Traffic Management 22

SPACE

- Celebrating 50 years of Innovation: ESA's Florence Congress Marks a Milestone 25
- How Sector-Agnostic Regulations Affect the European Space Supply Chain 29
- Product Assurance: the Silent Force Behind Copernicus Mission Success 34

CEAS JOURNALS

- CEAS Space Journal 38
- CEAS Aeronautical Journal 39

UPCOMING AEROSPACE EVENTS

45

EDITORIAL

Dear readers,

It is with great humility that I take upon me the task of editing the next Bulletins, a task that Jean-Pierre started many years ago and that Lukasz carried on last year. I thank the Board for the trust that has been placed in me, and I hope that in time the reader will feel this trust as well.

*The **Aerospace Europe Bulletin** has become the central place where the real story of European aerospace gets told: steady, often underreported progress spread across our member states, programmes and industry. Over the years we have had many insights from thought leaders as well as details from programmes that would otherwise remain in the background. This has given the community the sense of a common European journey towards a better tomorrow.*

It is there that I hope to make a difference for the readers. Not just by providing updates, but by providing perspective. A common thread through which the reader will understand the decision making, the history of technological developments and the evolution of things to come.

So it is with great pleasure to put before you a first edition of a new era and I hope you enjoy it.

Yours sincerely,



Thomas Vermin
Deputy Editor-in-Chief
AEROSPACE EUROPE Bulletin
ceas.bulletin.editor@ceas.org

President's report for the Year 2025



*Dr.-Ing. Cornelia Hillenherms
President of CEAS 2025*

It is a great honour and privilege to serve as CEAS President in 2025, and I am delighted to have been confirmed in the role for 2026.

The ultimate highlight in 2025 was undoubtedly the **CEAS/AIDAA Aerospace Europe Conference** in Turin, Italy, from 1–4 December 2025, kindly and generously hosted by AIDAA. Combining four parallel events, this was a truly significant conference for the European aerospace community. The 10th CEAS Aerospace Europe Conference coincided with the 28th AIDAA International Congress, the 10th Aerospace & Defense Meetings and the 9th Moon Village Association Workshop and Symposium. Participants from 37 countries worldwide – from Sweden to South Africa, and from Canada and Brazil to Korea and New Zealand – registered for the combined CEAS/AIDAA Aerospace Europe Conference, making it a global event.

Figure 1: Dr. Georges Bridel receives the CEAS Gold Award for his contributions to the aerospace industry



During the opening session we presented the **CEAS Gold Award 2024** to Georges Bridel and the **CEAS Distinguished Service Award 2024** to Pascale and Marc Sanfourche, daughter and son of Jean-Pierre Sanfourche, our long-standing Editor-in-Chief of the Aerospace Europe Bulletin. The fact that Jean-Pierre knew about this award before he passed away is a small consolation.

We were able to get the **Clean Aviation** Joint Undertaking (CAJU) Team to organise a plenary session with an overview by Maria Calvo Blanco, Head of CAJU Project Management, and presentations of selected successful aviation results from the programme. In addition to this plenary session, the conference provided a platform for ten other high-profile plenary speakers from the aerospace sector.

The Round Table "Women Trailblazers: Entrepreneurship in an Evolving Aerospace Ecosystem", which was co-organised by **Women in Aerospace Europe** and CEAS, brought together leading figures from various organisations to explore the current status and future development of the aeronautical and space sectors. It was the first action of the MoU between CEAS and Women in Aerospace Europe, which was signed immediately after the round table session. The session was moderated by Marie Antonietta Perino from Thales Alenia Space, who stepped in for Luisella Giulicchi at short notice, and me. The panellists were Prof. Melike Nikbay (Istanbul Technical University), Mariella Graziano (GMV Space Systems), Silvia Vela Ruiz (LegAire), and 'special guest' Amalia Ercoli Finzi. We had an inspiring discussion and received lots of positive feedback, especially from young people. By the way, this session, as well as all plenary sessions and parts of the opening ceremony, can be streamed on YouTube (see <https://www.aidaa.it/ceasaidaa2025/photo-videos/>).

As part of the MoU with **PEGASUS**, the Partnership of a European Group of Aeronautics and Space Universities, CEAS invited the best ten students of the PEGASUS spring conference, to present their papers at the CEAS-AIDAA Aerospace Europe Conference and to submit their papers to the CEAS Aeronautical or the CEAS Space Journal. As part of the ESA Academy Student Sponsorship scheme, CEAS has selected three more students to participate in the conference, with the ESA Academy covering the conference fees and travel costs.

In conclusion it can be said that the CEAS/AIDAA conference fully achieved its goal of bringing together diverse expertise, promoting scientific excellence and strengthening partnerships. The high level of international participation, the quality of the contributions and the dynamic activities of the student teams and professional exhibitors confirmed the vitality and ambition of today's aerospace community. On behalf of CEAS, I would like to thank all the participants, speakers, exhibitors and partners who contributed to the success of the event. Of course, a very big thank you goes to the main organiser, AIDAA and their great team!

Other activities / CEAS at work

General Assembly and Board of Trustees (BoT) Meetings

The General Assembly (GA) was held in Turin in December during the CEAS/AIDAA conference, while two BoT meetings took place, the first one in Prague in May, hosted by the Czech society, and the second one right after the GA in Turin in December.

The CEAS Officers appointed for 2026 are:

- Dr Cornelia Hillenherms CEAS President;
- Dr Łukasz Kiskowskiak Vice-President Publications and External Relations;
- Prof. Petter Krus Vice-President Awards and Membership;
- Mr. Philip Nickenig Vice-President Finance;
- Prof. Andrea Alaimo Director General;
- Prof. Jonathan Cooper Aeronautics Branch Chair;
- Mrs. Anastasia Pesce Space Branch Chair.

New members

Two new corporate members have joined CEAS:

- **SAE International** and
- **INCAS** National Institute for Aerospace Research "Elie Carafoli".

Two other entities, the Portuguese College of Aeronautical and Space Engineering and the Institute of Space Studies of Catalonia (IEEC), showed their interest in CEAS. We are currently in contact with them.

MoU-Partners

Several discussions and two meetings took place with **EASN** regarding MoU activities and actually the preparation of a paper on the European Research Framework Programme FP 10 (this statement has been published in January 2026 and is also included in this Bulletin issue). Although CEAS has decided to organise the next conference in 2027 in the traditional way, i.e. with one of its member societies rather than together with **EUCASS**, we will, of course, keep in touch,

The president of the Académie de l'air et de l'espace (**AAE**), Bruno Stoufflet, will be invited to the next CEAS Board-of-Trustees meeting to 'refresh' our MoU and to discuss further cooperation.

Informal exchanges with **ICAS**, **EREA** and **AIAA** also took place during the year.

Conferences & events

On the occasion of the **Aerodays 2025**, which took place in Warsaw from 7-9 May 2025, I had the opportunity to meet and talk to some of CEAS' partners, e.g. EASN and PEGASUS.

The **31st AIAA/CEAS Aeroacoustics Conference** took place in Las Vegas, USA, during the AIAA Aviation and

Figure 2. The session was moderated by Dr.-Ing. Cornelia Hillenherms, Marie Antonietta Perino from Thales Alenia Space, who stepped in for Luisella Giulicchi at short notice. The panellists were Prof. Melike Nikbay (Istanbul Technical University), Mariella Graziano (GMV Space Systems), Silvia Vela Ruiz (LegAire), with special guest Prof. Amalia Ercoli Finzi.



Aeronautics Forum and Exposition (2025 AIAA AVIATION Forum) from 21 – 25 July 2025. The conference was covered by the renewed agreement between CEAS and AIAA. Phil Joseph was awarded the **CEAS Aeroacoustics Award for 2025**, which highlights outstanding contributions to the field of aeroacoustics and acknowledges individuals and teams who have significantly advanced the understanding and mitigation of aircraft noise.

The **51st European Rotorcraft Forum ERF** took place in the historic Arsenale Militare of Venice, Italy, from 9 – 12 September with over 160 international speakers from industry, research institutions, academia, operators and regulatory agencies. I had the honour of giving a short welcome address on behalf of CEAS at the opening of the conference, where I emphasised the importance of this event for the community, highlighting that cooperation and openness are key European values that have led to, and will continue to lead to future success. As in previous years, the best papers from about a dozen authors have been invited to submit to the CEAS Aeronautical Journal for publication in a Special Issue.

The **4th International Conference on High-Speed Vehicle Science and Technology HiSST** took place in Tours, France, from 22 – 26 September, attracting 300 participants and 175 papers that were presented. It was organised in leadership of the CEAS member society 3AF (Association Aéronautique et Astronautique de France) and the CEAS Technical Committee HiSST. All conference papers will be uploaded to the CEAS repository and receive a DOI (digital object identifier). As in previous years, the best papers will be invited to submit to the CEAS Space Journal for publication in a Special Issue. In October 2025, CEAS Director General, Andrea Alaimo, was invited to present CEAS at the Swedish **FTF Congress** in Stockholm.

CEAS Awards

The **CEAS Gold Award 2025** has been assigned to **Sue Partridge** CEng FRAeS, Head of the Wing of Tomorrow Programme and Airbus Commercial Aircraft UK Country Manager, in recognition of her outstanding contribution to advancing aerospace art, science and engineering through her astute technical judgement, vision and leadership. Let me cite the referees:

"[...] Her work leading the Airbus Wing of Tomorrow Programme puts her as responsible for leading one of the biggest ever UK research programmes and draws together all the different aspects of Engineering, Innovation and Programme management. This involves leading the integration of new ways of working between Engineering Design and Manufacturing, working across the Engineering and Manufacturing supply chain and being the external face of Airbus Engineering for the programme in the UK - in front

of Government, the funders and the sector more widely. [...] she has been a constant inspiration to others and always used her knowledge and practical experience to encourage others to take up a career in engineering and aerospace. I have personal experience of her passion towards promoting diversity and apprenticeships in engineering and can fully endorse her position as a role model for girls and young women - a position earned through hard work and personal engagement. [...]"

The CEAS **Distinguished Service Award 2025** has been assigned to **Dr Uwe Möller**, Head of DLR Brussels office, in recognition of his exceptional and sustained contributions to the European aeronautics and aviation research and innovation ecosystem.

Over the last 25 years, the development of aeronautical research and technology in Europe has been guided by the Advisory Council for Aviation Research and Innovation in Europe (ACARE) and its visionary documents: 'European Aeronautics: A Vision for 2020' (2001), 'Flightpath 2050' (2011) and 'Fly the Green Deal' (2022). ACARE has produced a series of strategic research and innovation agendas to guide all European aviation sector stakeholders, including Member States, industry, research institutions, airlines, and various European bodies. Uwe has always been the central point of contact for organising activities and has been a kind of 'corporate memory' for ACARE. In this way, he has been, and continues to be, a key figure in the development of the European research and innovation programme for aerospace.

Unfortunately, neither award could not be presented at the CEAS/AIDAA conference in Turin, as both recipients were unable to attend for various reasons. They will be presented at appropriate events this year.

I would also like to mention the recipients of the most cited journal paper awards, with just one paper per journal (since last year).

The **2025 Most Cited Paper Award for the CEAS Aeronautical Journal** goes to:

Anna Straubinger, Johannes Michelmann & Tobias Biehle.

- **Business model options for passenger urban air mobility.**

CEAS Aeronautical Journal, 12(2), pp. 361–380 (2021).
<https://doi.org/10.1007/s13272-021-00514-w>

The **2025 Most Cited Paper Award for the CEAS Space Journal** goes to:

Advenit Makaya, Laurent Pambaguian, Tommaso Ghidini, Thomas Rohr, Ugo Lafont & Alexandre Meurisse.

- **Towards out of earth manufacturing: overview of the ESA materials and processes activities on manufacturing in space.**

CEAS Space Journal, 15 (1), pp. 69–75 (2023).
<https://doi.org/10.1007/s12567-022-00428-1>

Journals

The **CEAS Aeronautical Journal** has been accepted into the Web of Science in September 2025! Like its companion journal, the **CEAS Space Journal**, it has been included in Clarivate's Emerging Sources Citation Index. This is a significant achievement, and we are very proud that both CEAS journals are now indexed by Scopus and WoS – the two most recognised platforms. Since 2025, Prof. Franco Bernelli is the Editor-in-Chief of the CEAS Space Journal, following Prof. Hansjörg Dittus.

• Some numbers:

In 2025, a total of 271 / 213 manuscripts were submitted to the CEAS Aeronautical / Space Journal and 112 / 101 papers (some of which had also been submitted earlier) were accepted.

Aerospace Europe Bulletin

I'm very grateful to Łukasz Kizskowiak, who stepped in as Acting Editor-in-Chief after the sudden death of our long-standing Editor-in-Chief, Jean-Pierre Sanfourche. He produced two excellent issues of the Bulletin in 2025 alongside all his other duties.

At our last BoT meeting in Turin in December, we decided to appoint Thomas Vermin, as the new Editor-in-Chief of the Bulletin. We look forward to working with Thomas and thank him for his commitment!

Thank you for your continued commitment to promoting aerospace in Europe and beyond, in the spirit of freedom, mobility, peaceful coexistence and an environmentally friendly and sustainable future!

Cornelia Hillenherms
President of CEAS
Cologne, 2nd March 2026



Innovation, Collaboration, and Global Engagement at the CEAS-AIDAA Conference 2025

By Erasmo Carrera and Matteo Filippi, Italian Association of Aeronautics and Astronautics (AIDAA)

The 28th AIDAA Congress and the 10th CEAS Aerospace Europe Conference took place in Turin from 1-4 December 2025 at the Centro Congressi Lingotto, formerly FIAT's first car factory, bringing together more than 700 participants from Europe and from across the world. Researchers, engineers, industry representatives, institutional delegates, and members of the aerospace community gathered for four days of scientific exchange and strategic dialogue.

Jointly organized by the Italian Association of Aeronautics and Astronautics (AIDAA), a CEAS member society, and the Council of European Aerospace Societies (CEAS), the conference united two major organizations in the aerospace sector. The conference program offered a broad overview of contemporary aeronautics and space research. The nearly 700 contributions received covered key areas such as aerodynamics, advanced materials, structural dynamics, innovative aircraft and rotorcraft concepts, sustainable and green propulsion, mission and space systems design, GNC, avionics, and UAV/UAM applications.

Exciting lectures and dynamic exhibition

Digital innovation also featured prominently, with papers on AI, modelling and simulation, digital twins, virtual testing, and advanced manufacturing. Several focused special sessions explored frontier topics including novel materials, space sector industrialization, VLEO missions, structural health monitoring, GNSS advances, next-generation spacecraft, sustainable aircraft concepts, and additive manufacturing. The scientific program was further enriched by high-level plenary speakers, who opened each day with strategic insights and forward-looking perspectives.

A dedicated **Exhibition Area** added a vibrant and engaging dimension to the conference, bringing together a wide range of contributors within a single dynamic space. The area featured **industry partners**, including companies, research centers, and institutions, who presented advanced technologies, demonstrators, and ongoing aerospace programs, offering valuable technical insights and collaboration opportunities.

Sharing the same space, **student teams** from Italy and from abroad, including India, Mexico, and Poland, showcased innovative prototypes, experimental platforms, and conceptual designs. Their creativity and international perspectives complemented the professional exhibits, making the Exhibition Area a lively environment where experience, research, and emerging talent converged.

From Moon Village to Aerospace & Defense

In addition, the conference **hosted the 9th Moon Village Association Workshop and Symposium**, adding a dedicated international forum on the future of lunar exploration. The MVA gathering brought together experts from multiple sectors, broadening the scope of discussions and contributing valuable global perspectives to the week's activities.

During the same days, the **Aerospace & Defense Meeting (A&DM) Torino** was held at the nearby Oval Lingotto, featuring hundreds of targeted business-to-business meetings and attracting participants from more than 35 nations. The parallel presence of A&DM and the CEAS-AIDAA conference fostered a naturally interconnected atmosphere, with participants engaging across both events and benefiting from an expanded landscape of scientific, technical, and industrial exchanges.

Successful conference in Turin

Turin, recognized as one of Europe's leading aerospace hubs, proved to be an excellent setting for the event. Its blend of industrial heritage, strong academic institutions, and vibrant innovation ecosystem provided an inspiring backdrop for both discussions and networking.

The CEAS-AIDAA Conference fully achieved its goal of uniting diverse expertise, promoting scientific excellence, and fostering meaningful partnerships. The strong global participation, the high quality of the contributions, and the dynamic activity across both student teams and professional exhibitors confirmed the vitality and ambition of today's aerospace community.

The organizers extend their sincere appreciation to all participants, speakers, exhibitors, and partners who contributed to the success of the event. The momentum generated in Turin will continue guiding the international effort to shape a sustainable, innovative, and forward-looking future for aeronautics and space.

Plenary sessions

- Heritage and Horizon: Helping to shape the Future of Flight, **Luís Carlos Affonso** (Embraer)
- Past, Present and Future of Space Pressurized Module, **Walter Cugno** (Thales Alenia Space)
- Space It Up: The Italian consortium for space science and technology, **Antonio Moccia** (Space It Up)
- Smart Morphing Structures and Applications in Aerospace, **Jinsong Leng** (Harbin Institute of Technology)
- Competitiveness. Sustainability. Technology. Clean Aviation Strategy to tackle aviation's top three challenges, **María Calvo Blanco** (Clean Aviation)
- Aerodynamics and Aeroelasticity of Innovative Wing Systems, **Luciano Demasi** (San Diego State University)
- Entrepreneurs' occupation of low-Earth orbital space and its environmental impact, **Patrizia Caraveo** (INAF IASF-Milano, Istituto di Astrofisica Spaziale e Fisica cosmica Milano)
- Laminar Flow – Reducing the Energy Required for Flight, **Scott Drennan** (Otto Aviation)
- Hydrogen as future energy source for aviation, **Markus Fischer** (German Aerospace Center (DLR))
- Hybrid-Electric Bridging to a Sustainable Aviation Future, **Susan Ying** (EL-Fly Group)
- From standard platforms to autonomous constellations, **Andrea Accomazzo** (Argotec Group)



Dr Erasmo Carrera is a Professor of Aerospace Structures and Aeroelasticity at the Politecnico di Torino. He is Past President of the Italian Association of Aeronautics and Astronautics (A.I.D.A.A.). His main research topics include composite materials, finite elements, smart structures, thermal stress, aeroelasticity, multibody dynamics, and the design and analysis of non-classical lifting systems. Dr Carrera serves as a contributing editor for several international journals. He has authored and co-authored around 800 scientific papers, organised numerous large conferences, and received various awards. Notably, he was awarded the title of Commander of the Order of Merit of the Italian Republic.



Dr Matteo Filippi is an Associate Professor in the Department of Mechanical and Aerospace Engineering at the Politecnico di Torino. His research field includes aeroelasticity, finite element analysis, higher-order theories, nonlinear dynamics as well as rotor dynamics.

Impressions of the Aerospace Europe 2025 Conference



CEAS/EASN Statement on the next Framework Programme for Research and Innovation (FP10)



The European Union is currently setting the course for the next Framework Programme for Research and Innovation (FP10), which will begin in 2028. We acknowledge the Commission's efforts to simplify and streamline processes.

However, we would like to take this opportunity to share our thoughts on some aspects we consider to be particularly important.

- **FP10 should** stand for excellent science and technology, reliable funding programmes, and robust collaborative research.

- **Funding programmes should** be aligned efficiently to cover the entire innovation chain, from basic and applied research to (market-oriented) technology development.

This alignment should include environmental, social and economic sustainability across the entire innovation process to enhance competitiveness and strengthen prosperity and strategic autonomy of Europe.

- **A reliable and strong long-term funding** framework and related tools, as well as sufficient funding, are needed for the European Research Area to support scientific research at universities and research and technology organisations, enabling them to remain internationally competitive.

- **One of the essential strengths** of the European research landscape lies in Collaborative Research, which is represented in the second pillar of FP10, bringing together universities, non-university institutions and industry, including SMEs, across national borders. It is vital that in the future, funding is not limited to short-term economic gain.

- **The FP10 programme should** not be constrained by the envisaged European Competitiveness Fund with respect to its objectives and governance, enabling synergies where appropriate.

For CEAS:

Cornelia Hillenherms (President)
Andrea Alaimo (Director General)
Svjetlana Stekovic (Trustee)

FOR EASN:

Andreas Strohmayer (Chairman)
Spiros Pantelakis (Honorary Chairman)
Helge Pfeiffer (Secretary General)

Interview with Assoc. Professor Sjoerd W. Rienstra



This February we sat down with Professor Sjoerd W. Rienstra, expert in the field of aeroacoustics and former chairman of the CEAS Aeroacoustics Committee and winner of the CEAS Aeroacoustics Award, to talk about his long career and his insights into the field of Aeroacoustics.

Aeroacoustics encompasses the bordering regions of steady and unsteady aerodynamics (turbulence and instabilities), and acoustics in both uniform, non-uniform and highly non-uniform media. The acoustic, aerodynamic, atmospheric, and structural length scales vary considerably and also diverge significantly. There are so many dimensionless parameters involved that scaled-model tests are hardly possible. To keep Mach, Reynolds, Strouhal and Helmholtz numbers the same as in the real problem, all problem parameters must be the same. Therefore, full-scale wind tunnel tests are necessary. These are expensive, and therefore create a need for theoretical models to contribute to the development of the field.

First of all, thank you for taking the time to sit down with us. Can you tell the readers a bit about your background? How did you end up in this field and at TU Eindhoven?

In short, I studied mathematics in Utrecht, did a PhD in physics in Eindhoven, worked at the National Aerospace Center (NLR) on aircraft noise control (mainly turbofan engines), and then returned - via a short period at the university of Nijmegen - to Eindhoven, now at the mathematics department.

Early on, during my study in Utrecht, I became especially interested in applied analysis - and later in asymptotic methods. What I found attractive about asymptotic methods was that it gave insight: you could begin to understand what was happening, not just compute numbers. That was also where I started to appreciate modelling more deeply. In a way, asymptotic analysis is also modelling - just with different tools. You make assumptions, simplify in a structured way, and try to capture the essential behaviour.

Later, after my graduation, my attention was attracted by a PhD position opened up in Eindhoven in the Physics department on a subject that fascinated me right from the start, the interaction between sound and flow. There were experiments, but people did not really understand what was happening. They wanted someone with a different perspective to work on it. I applied, and was accepted straightaway.

So there I ended up in aeroacoustics - but I came in as a mathematician, not as someone with a classical fluid mechanics/acoustics background.

How did your research develop from there?

My professor at the time (who was the rector of the university) had planned to finish his rectorship to supervise me more closely, but because of the university situation in those years - student unrest, great administrative changes - he had no successor. He had to stay on as rector, and therefore had very little time for me. At one point he basically told me: "You'll have to find your own way. I can give you maybe 20 minutes every two weeks."

So I started with a literature study, and was subsequently sent on a study trip of my own choice along the leading experts in theoretical aeroacoustics of England. I visited people whose work I had been reading - first in London and then Cambridge, where I was redirected by Sean Ffowcs Williams to Leeds, to see David Crighton.

That meeting was a turning point. I explained what I had been trying to do and how I was thinking about the problem. He pulled out a notebook and showed me notes that matched almost exactly the ideas I had just described. That was a very important moment - because then you realize: this way of thinking is valid. I told him, "I just don't know how to proceed." And he said, essentially, "Then let's start here" and suggested a first problem to work on.

I remember saying, "But this has already been done - it's in the literature." And he said, "Yes, you're right - but do it anyway", which was very good advice. A young PhD student is simply not able to understand a research paper only by reading it. You first have to struggle with the problem yourself. Later I summarized this to my own students as the maxim "Literature study is done afterwards."

You mentioned experiments people didn't really understand. What kind of experiments were these?

They were about the coupling between sound and a jet – in that case a 2D under-expanded supersonic jet. That coupling can produce what is called jet screech.

Very roughly explained, when the jet becomes unstable it starts to oscillate and those oscillations generate sound pulses. These pulses travel also upstream and interact again with the jet shear layer, producing vortices and a feedback loop. With high-speed photography they could already see parts of this process happening but they did not fully understand them.

This was interesting in its own right, but also because these kinds of phenomena were relevant in the wider aviation world. For example, jet screech was an important type of noise of the Concorde and its Olympus engines. Guided by David Crighton who became my second PhD supervisor, my PhD work (focusing on the trailing edge) gained substance. I achieved my doctoral degree, produced some publications, and eventually I went to NLR. They saw my thesis and thought, perhaps, that I knew much more of aeroacoustics than I really did. In reality, I still had to learn a lot.

I was trained as a mathematician. I remember asking very basic engineering questions that others thought were obvious. People found that strange, but I didn't see why I shouldn't ask. If I didn't know, then I didn't know.

At NLR I grew into the field and built up a network, including many international contacts. That was very exciting, but I also felt a bit constrained: I wanted to work not only on the industry project of the moment but also on questions I found genuinely interesting when I saw possibilities for answers. Progress in deep problems is only made by first simplifying its essence to the level of a ridiculous toy problem. In industry, there is, unfortunately, not always enough time to appreciate that.

Later I moved to Nijmegen (to a broader applied mathematics group), but that was in some ways too theoretical for what I wanted. Eventually I had the opportunity to return to Eindhoven, and there I gradually redeveloped and continued my own lines of research in theoretical aeroacoustics.

If you look at my publication list, you can see a gap – a long period between my PhD and when I really picked up things in aeroacoustics again. In a way, I did my post-doc research later than usual. That happens sometimes, but eventually you find your way.

Did you feel that that at the Eindhoven University of Technology you could finally pursue the ideas you had wanted to explore?

In hindsight, yes – but at the time, life is never that linear. Many things play a role: colleagues, collaborations that work or don't work, institutional constraints, and so on. One thing I have always resisted is the idea of a project where the outcome is already promised. To me, that is either not interesting, or simply impossible. Of course, industry often wants predictability – understandably. But real research does not work that way. Often you only know what was important after you've done it.

Are there a few projects during that time that stand out to you personally?

Yes, three in particular.

The first one was sound propagation in slowly varying modes in flow ducts. I was able to develop a theory for sound waves (modes) in channels with slowly varying flow and wall properties (typical of the inlet and bypass duct of turbofan engines). I found that very satisfying because it fits beautifully with ideas I knew from asymptotic analysis in mathematics.

At the time, I published it initially in a rather obscure place because I thought it was not so important. Then, about ten years later, someone at a conference, who was working on something similar, showed me his work. I said, "But you can do that directly, I did that years ago." The response was a bewildered: "Where did you say this was published?" So I ended up rewriting it in a slightly updated form, to publish it in a much more visible journal. That was a lesson in how badly one can judge one's own work. It became my most cited paper.

The second one is the explanation of the then un-understood occurrence of "strange modes" in lined ducts. Since they behave so erratic, different from the other modes, they were notoriously hard to find. I realized that these modes should be interpreted as surface waves, decaying exponentially away from the liner surface, not unlike ocean waves along the water surface, or Rayleigh waves in seismology along the earth's surface. That classification made the behaviour much clearer and predictable and helped explain why they were hard to find numerically. That paper became one of my most-cited works, largely because it gave people conceptual understanding.

A third contribution came from a European project. The issue was: we have a liner-impedance description in the frequency domain, but the computer code works in

time domain. How do you convert the impedance from frequency to time in a mathematically consistent and physically correct way? To me, it reminded me of a classical problem (with ramifications in quantum mechanics), so I wrote down a list of conditions for the impedance function to be physical and an example of an implementation, and presented it at a conference. I did not even turn it into a decent journal paper. In hindsight this was probably silly because the paper ended up in the top of my citation list. Sometimes something that feels "standard" to you is exactly what another community needs.

You have also done a tremendous amount of work within European context and for the CEAS Aeroacoustics Committee. How did that develop?

By that time I was already back in Eindhoven, but still had a network from NLR, including international contacts. Then, when the Aeroacoustics Specialist Committee (ASC) was created in 1995, they wanted representatives not only from industry and national labs, but also from universities. In the Netherlands, I was one of the obvious candidates, so I was asked to join. Later I even served as chair for a period.

That helped a lot. Through the committee and conferences, and later through EU projects, you stay in touch with what industry needs, what research labs are doing, and where universities can contribute.

Was there a clear structure to how the field developed, or was it more fragmented?

The committee itself was mainly organizational. Industry has concrete targets. For example, the gradually becoming stricter ICAO noise requirements enforces each new aircraft generation to reduce noise by another few decibels. Those needs create new questions, which flow to research labs, and then sometimes to universities.

But no, scientific progress itself is not plannable like the production of a factory. I often compare this to the history of electricity. It didn't begin because a funding body issued a call saying, "Please invent electricity for better lamps." It began with curious people playing with (seemingly) totally unrelated phenomena like frog legs, and noticing something interesting. Much later, others recognized how to build systems and technologies on top of it.

The same is true in our field. Most work will not lead directly to a breakthrough. But sometimes a small piece of understanding turns out to be crucial.

Have you seen the focus in aeroacoustics change over time?

Yes, in many ways. With apologies for the fact that I know my own field best, an example is a striking change in the last 15–20 years in how people obtain the impedance of a liner. The quality of this seemingly innocent parameter in our model is starting to lag behind the rest of the modelling. The usual characterization of a liner, as a (location-dependent) impedance, is a local 1D description, averaged over a piece of liner surface. This is valid without flow, for low amplitudes, and for cells much smaller than the typical acoustic wavelength. I remember the days that the sound is measured in situ, in the cell itself, from which the effective impedance seen from outside is determined. But the more general case that we need in aircraft engine applications is quite far removed from this physical reality.

Traditionally, impedance was something you tried to derive from physics: understand the mechanism, then distill an impedance model from that understanding. But in practice this became extremely difficult because of flow effects, turbulence, possibly nonlinear behaviour at high sound levels, and complicated liner geometries.

So what many people now do is effectively a form of backward engineering, an inverse approach: assume a relatively simple wave model in the duct, assume there is some effective impedance at the duct wall. Then determine the prevailing acoustic field in parallel experimentally and numerically, while tuning the impedance in the model until the simulated field matches the measured field.

That always gave me a mixture of confusion and curiosity. On one hand I thought, "This is just curve-fitting – where is the physics?" On the other hand, it works, and sometimes it is the only workable route.

Why are liners are hard to model physically?

The details are very complicated. Liners are constrained by structural and safety requirements, so they are often made from cellular (honeycomb-like) structures with perforated face sheets. At high amplitudes, flow moves in and out through the holes, creating jets that interact strongly with the mean flow and boundary layers.

Those interactions are exactly the kind of thing that is not captured well in the simple impedance picture – at least not from first principles in a clean way.

So yes, there is still a lot to be gained there.

Do you see AI playing a role in that?

Potentially, yes. If the full physical model is too complicated or unknown, one could imagine using AI, like neural networks, to recognize effective behaviour from patterns in data – especially if people are already working with inverse identification methods anyway. The high frequencies and the coupling with all sorts of details prevent us from modelling many things numerically, let alone that we don't yet know the precise physics in the first place. I'm not an AI expert and it is difficult to predict the future, but it seems logical to try to tackle by AI the parts that we cannot model from first principles.

For a rationalist, this may be somewhat unsatisfying, but if you only use what you fully understand, we wouldn't be able to fly very far. For what it's worth, according to the Millennium Prize Problem on the Navier-Stokes equations, the mathematical proof for the existence of well-behaved solutions to the Navier-Stokes equation still only holds for a finite time interval. Yet we cross the ocean by plane. The key question would be whether AI gives only a better fit, or also better insight. But given how difficult the detailed physics is, I can certainly imagine AI becoming part of the solution.

How central is noise really in aircraft development compared to efficiency and safety?

Safety is always first. After that, noise matters a lot because of certification and regulations. An aircraft has to meet noise limits before it is allowed to be sold, and that has to be addressed already at the design stage. Once the aircraft is built, there is only so much you can still change. This means that a lot of theoretical modelling in advance is necessary.

Economics also matters, of course – airlines want efficient aircraft – but there isn't a certification barrier in the same way there are for safety and noise.

I have sometimes suspected (and this is partly my interpretation from the outside) that the worldwide noise standards also act as a competitive barrier. If a manufacturer cannot meet ICAO noise standards, international market access is impossible.

You can see, for example, how active China has become in aeroacoustics by publications and international conferences over recent years. This is not accidental. They clearly want to reach the level needed to compete globally.

What other developments do you see happening in the near future?

The previously noisy jet engine with bypass is now so quiet, after 60 years of steady noise reduction (mainly by increasing the bypass ratio), that airframe noise dominates during landing. So we are working hard on that noise source as well. Nature proves that further reduction should be possible. There is a large gap between what current aircraft do and what (all scaled, of course) nature is capable of, e.g., for birds of prey, owls, and *mutatis mutandis* dolphins, orcas, etc. The structure of an aircraft is very stiff (unlike the feathers of a bird or the skin of a marine animal), and that will hinder the necessary adaptation to turbulent flow, vortex shedding, and other interactions of vortices with edges and hard objects (all of which produce noise). Therefore, if and when this gap can be closed is difficult to predict.

Thank you for your time. Is there anything else you'd want readers to take away?

I liked to work in the triple point between relatively fancy applied mathematics, classical physics and the glamour of aircraft engineering, appealing to everybody. Making some small contributions is fascinating, stimulating and fun, but otherwise the real achievements in aeroacoustics are a worldwide project driven by the visionary founders of the UN agency called ICAO who nailed the slowly stricter Noise Certification Standards that make aircraft quieter by being predictable and fair for the industry. I am proud to be part of that project.

I was very pleased to receive some time ago the CEAS Aeroacoustics Award. I appreciated it especially because in a mathematics department, colleagues know each other from their field in math, not their field of application. So when working on a niche topic that theoretical aeroacoustics is, you are inevitably somewhat isolated. Recognition then means something.

Be seen and be aware – Preventing Mid-Air Collisions in General Aviation

By Dr.-Ing. Klausdieter Pahlke, Philippe Plantin de Hugues & Dr. rer. nat. Niklas Peinecke

Safety data 2009 - 2019

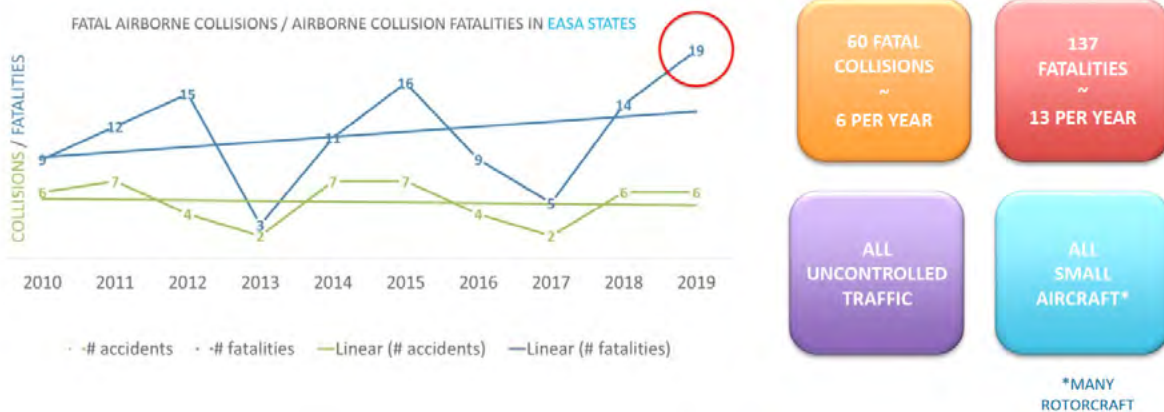

Figure 1: Fatal Mid-Air Collisions in EASA Member States

According to the European Union Aviation Safety Agency (EASA), an average of six fatal mid-air collisions involving General Aviation (GA) aircraft occur each year in Europe, resulting in approximately 13 fatalities annually. Nearly every experienced GA and ULM (Ultralight Motorized) pilot has encountered at least one near mid-air collision – and it happens more and more often. As part of the ongoing cooperation between the Air and Space Academy (Académie de l'Air et de l'Espace, AAE) and German Society for Aeronautics and Astronautics (Deutsche Gesellschaft für Luft-und Raumfahrt, DGLR), a decision was made in 2021 to establish a working group focused on preventing mid-air collisions in GA. The need to address this issue was identified as a top priority by both AAE/DGLR members and EASA, which also highlighted it as a safety priority in its European Plan for Aviation Safety.

New players and new technologies are entering the airspace: Powerful ultra-light aircraft that increasingly outperform some conventional GA aircraft; new electric aircraft types, including eVTOLs (electric vertical take-off and landing); remotely piloted aircraft (RPAS) and other UAS (Unmanned Aircraft Systems), operating or expected to operate within the framework for the unmanned air traffic management called U-space, and UAS BVLOS

(Beyond Visual Line of Sight) operations outside U-space. All of these aircraft often lack certified collision avoidance systems such as TCAS (Traffic Alert and Collision Avoidance System), due to cost, size, weight constraints, and an absence of regulatory mandates.

Collision Avoidance for ULs, gliders and drones

However, many GA aircraft, including ultra lights (ULs) and gliders, are equipped with lightweight, uncertified low-cost traffic awareness and anti-collision systems. One notable system is FLARM (Flight Alarm), a proprietary technology developed starting in 2004, initially specifically for gliders. Designed to accommodate the unique needs of small aircraft, such as frequent flight path changes, limited space, and minimal power, it has seen widespread voluntary adoption, especially among glider pilots. Despite using a proprietary radio protocol and only detecting similarly equipped aircraft, FLARM has significantly reduced mid-air collisions within the gliding community. Since then, there were numerous other protocols (open and proprietary) developed by other companies, most notably the open-source software FANET, which offers an air-based ad-hoc network func-



Figure 2: The airspace will continue to fill up in the future. Perhaps soon even with air taxis, as this artificial representation over Hamburg shows. © DLR

tionality, and PilotAware, that allows ground-based re-routing of network packages.

While FLARM and its alternatives have found a broader acceptance in the glider and UL community, the drone community has developed their own standards. Starting from 1st January 2024, it is mandatory for drones in the open category to implement the Direct Remote Identification (DRI). With DRI each drone is required to submit its own identification and position via Wi-Fi or Bluetooth to its surroundings. A relay of this information via mobile networks was proposed but not yet included in the current standard. Prior to DRI a number of proprietary systems have been used, most notably solutions like DJI Aeroscope, which has been effectively discontinued with the introduction of DRI.



Figure 3: Wreckage of a DR400 after a collision with a ULM on approach to Lunéville-Croismare Airport in France. The collision without fatal injuries was due to the use of different radio frequencies. Source: Police de Lunéville

Flying in the same airspace

Yet, a fundamental problem remains: the lack of interoperability among these anti-collision systems. Because these systems use varying communication protocols, they often fail to detect each other, rendering them ineffective in mixed-traffic environments. In contrast to ADS-B (Automatic Dependent Surveillance – Broadcast), a method used for the rest of aviation, most of these systems operate independently of any ground infrastructure. This is cost-effective and simple but limits situational awareness of traffic outside the aircraft's detection range. The broad diversity and performance characteristics of GA aircraft make it difficult to apply a one-size-fits-all solution like the original FLARM for gliders.

At the same time, the evolution of U-space, the traffic management system for drones in Europe, makes it necessary to integrate GA into these systems, too. U-space is a system of systems approach that, among others, makes drones and their operators aware of other drones. Typically, UAS are too small to carry certified transponders. Furthermore, these ADS-B transponders are too expensive compared to the overall costs of a low budget drone. Therefore, most drones implement their own, low-cost electronic conspicuity solution and relay the information to a U-space service that can be interrogated by other airspace participants. In airspace that is accessible to GA as well like the uncontrolled airspace class G, it is necessary that GA aircraft and drones make themselves known to each other and are visible to drone operators. This can be achieved by providing the information from an active electronic conspicuity system to the respective U-space service. While this is already possible with FLARM and its siblings, an open standardization would be beneficial for U-space evolution.

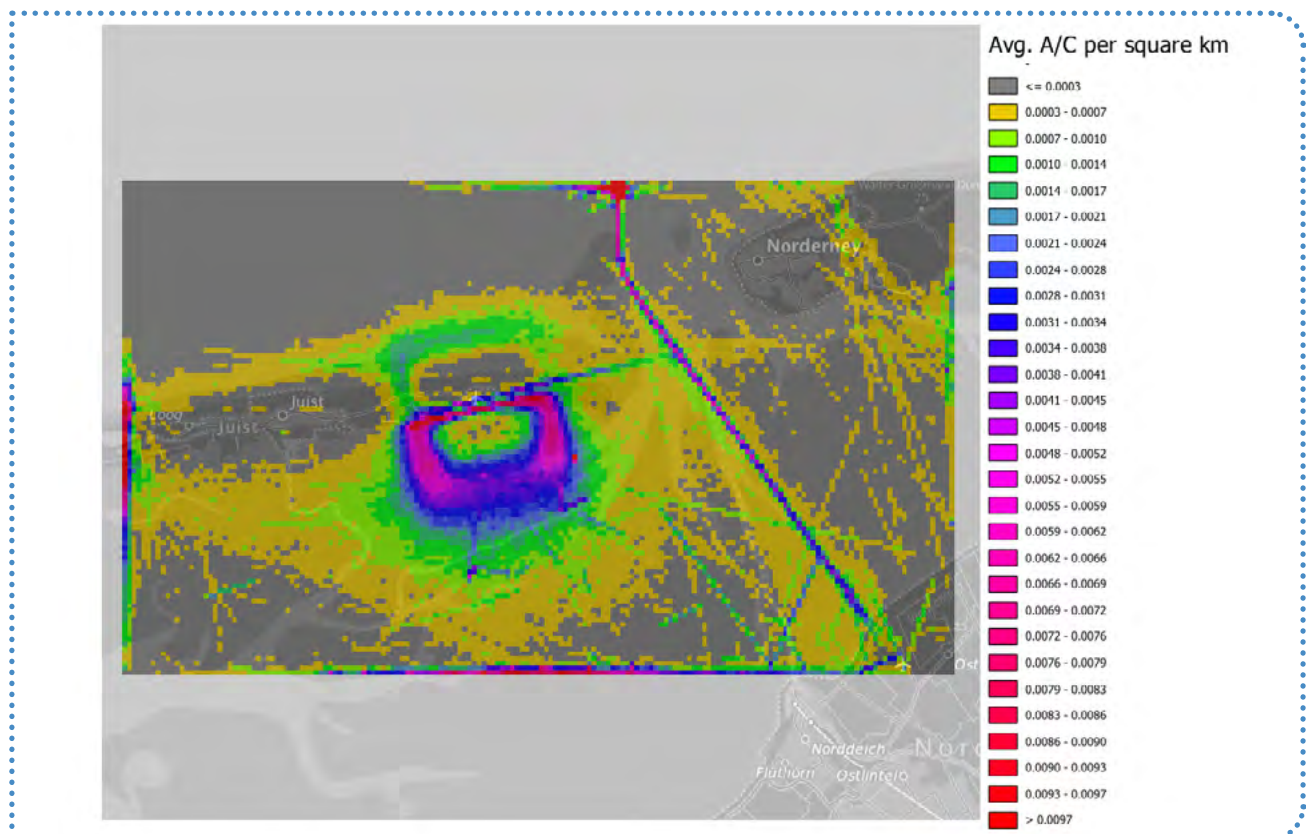

Figure 4: Traffic density in the airspace G around the island Juist. The data shown has been assessed in the course of 2022 using data from ADS-B, FLARM and ground-based radar, but it can be assumed that some unequipped aircraft are omitted in this data set. © EASA

A secondary aspect of electronic conspicuity lies in its usefulness for the commercial use of the class G airspace. With the development of commercial drone applications like infrastructure inspection and protection, package delivery and medical transports, and with the possibility of passenger transport in unmanned vehicles (UAM and IAM, Innovative Air Mobility), it is necessary to gather more data about the actual traffic density in this airspace. This includes gliders and UL. Since electronic conspicuity is not mandatory, these data are not yet available for most areas. With a more developed and standardized solution for electronic conspicuity a more detailed knowledge about traffic densities in airspace G is possible.

Analysing data

The AAE/DGLR working group, comprising GA pilots, commercial pilots, engineers, and safety investigators, conducted a multidisciplinary assessment to identify the most appropriate methods for reducing collision risks in non-TCAS-equipped aircraft. The group also leveraged its familiarity with French developers of systems to improve situational awareness and help avoid collisions, particularly for gliders.

The initial task was to analyse the frequency and na-

ture of mid-air collisions in France, the UK, Germany, and the United States. The team contacted relevant accident investigation authorities to obtain data and reports on such incidents, including collisions involving GA aircraft, ULs, gliders, helicopters, and remotely controlled aircraft. Many of these accidents occurred in good weather and visibility, raising questions about the equipment. In most cases, aircraft involved either had no collision avoidance system or systems that were incompatible with each other, meaning no alert was issued to the pilots.

To guide the work, a clear set of Terms of Reference was established:

- Analyse mid-air collision risks by type of aircraft and operation;
- summarize existing and emerging technologies or procedures for mid-air collision prevention;
- assess advantages and limitations of current systems;
- define system capabilities, whether to support "see and avoid" or provide active avoidance solutions;
- establish a rationale to inform AAE/DGLR recommendations;
- develop practical recommendations for procedures or systems installations that maximize interoperability and safety in small aircraft.

Barriers for anti-collision systems

The group also reviewed national initiatives and strategy papers related to mid-air collision reduction and consulted with stakeholders to understand why promising concepts often fail to reach implementation. A partial answer can be found in an EASA survey which highlights the main barriers for GA pilots/owners in adopting anti-collision systems: high cost (48 per cent), lack of compatibility (26 per cent), and installation complexity (10 per cent).

Parallel to the AAE/DGLR initiative, EASA launched a project (2022–2024) focused on the interoperability of electronic conspicuity systems for GA. Its objective was to develop a recommended standard for communication among such systems. The project's key deliverable is a comprehensive roadmap for the development of technical standards that enhance interoperability, ultimately contributing to reduced collision risk in uncontrolled airspace.

The AAE/DGLR working group actively contributed to this project through consultations, discussions with EASA, collaboration with French and German authorities, and participation in public reviews of regulatory proposals. It quickly became evident that interoperability affordability (low cost to end user) and privacy is the key for success. Therefore, a structured approach was required to define interoperability levels, necessary requirements, and pathways for integrating these systems within the existing GA ecosystem.

A system that fits all

Work by EASA highlighted that equipping aircraft with ADS-L (Automatic Dependent Surveillance-Light) systems enhances electronic conspicuity, making all airspace users more visible and promote the concept of "Be Seen and Be Aware.". ADS-L is a protocol to which manufacturers of devices intended to increase electronic conspicuity subscribe. ADS-L is an affordable, interoperable GNSS-based system (Global Navigation Satellite System) that supports privacy and security. EASA promotes its adoption through the ADS-L Coalition, encouraging industry-wide participation.

Regarding privacy, EASA and NAAs (National Aviation Authorities) announced the iConspicuity Declaration initiative during AERO 2025. In this initiative, EASA, national aviation authorities, and general aviation associations jointly express their commitment to promote the development of iConspicuity Devices and their use and exploitation of related data. The objective of this initiative is to enhance aviation safety, foster innovation, and improve operational efficiency through collaborative analysis. As drone traffic grows in U-space, conspicuity is key to safe coexistence. Being aware also means using flight tools and visual scanning techniques effec-

tively. Technology aids situational awareness must be balanced with traditional lookout practices. Ultimately, combining the right equipment with disciplined awareness helps every pilot *#flyanotherday*.



Please see the Event Materials section on the EASA event website for further information: [Link 1](#), [Link 2](#)

Authors:

- **Dr.-Ing. Klausdieter Pahlke** is Head of the Helicopter Department at the Institute of Flight Systems at the German Aerospace Center (DLR). The department specialises in aeromechanics, rotor technologies, wind tunnel test technology, flight mechanics/handling qualities and flight control/pilot assistance. He is national representative in the European Rotorcraft Forum International Committee, member of the GARTEUR Group of Responsables Rotorcraft, author of numerous publications in the field of rotorcraft research, holder of the German Aviation Badge of Honour and Technical Fellow of the Vertical Flight Society.

- **Philippe Plantin de Hugues** is Head of European and International Affairs and Senior Investigator at the Bureau d'Enquêtes et d'Analyses pour la sécurité de l'aviation civile (BEA) in France. After obtaining his Ph.D. in Fluid Mechanics and completing a year at NASA's Ames Research Center (USA), he joined the BEA in 1993. As an audio specialist, he has contributed to major international investigations involving France, working on more than 800 events worldwide. He has chaired several international working groups, including an ICAO panel, focusing on flight recorders, location of aircraft in distress, flight data recovery.

- **Dr Niklas Peinecke** is group leader for drone security at the Institute of Flight Guidance at the German Aerospace Center (DLR) in Braunschweig, Germany. He received his doctorate in computer science from Leibniz Universität Hannover in 2005 and is co-inventor of methods for 3D shape classification and efficient conflict detection. Since 2007 he has been working at DLR in the fields of sensor simulation, displays and detect-and-avoid. His other research interests include computational geometry and computer graphics. He was project leader for the DLR parts of several national and EU-funded projects.

FASTNet: developing data-driven solutions for air traffic management



As Europe faces increasing air traffic demands and climate efficiency challenges, the SESAR Joint Undertaking's FASTNet project has recently performed a series of validation exercises demonstrating how smarter data use and enhanced airport-network coordination can make operations more predictable, efficient and resilient — from months in advance through to the day of operations. FASTNet – short for Future dATA Services and applications for airports and Network – brings together European airports, airspace users, industry and EUROCONTROL's Network Manager to improve the way we manage air traffic. The project focuses on enhancing collaboration and data sharing between airports, airlines and the wider European air traffic management network (EATMN).

At the heart of FASTNet are two complementary SESAR solutions addressing different planning horizons:

- **Enhanced AOPs-NOP tactical planning (Solution 346)**, targeting the tactical, day-of-operations phase.
- **AOP-NOP data enhancement to the strategic (from months in advance until D-7) and pre-tactical (D-7; D-1) planning phases (Solution 347)**, focusing on strategic and pre-tactical phases (from months in advance until D-1),

Together, they demonstrate how data-driven insights and targeted coordination can replace broad, system-wide measures with smarter, more precise interventions.

Replacing blanket restrictions with targeted flight management

Solution 346 focuses on improving coordination during the tactical phase — on the day of operations.

Traditionally, when an airport experiences a capacity shortfall, broad Air Traffic Flow & Capacity Management (ATFCM) regulations may delay all inbound traffic. FASTNet proposes a more refined alternative.

This "cherry-picking" approach enables airports to coordinate directly to identify and adjust only the specific flights that can resolve bottlenecks — instead of applying blanket restrictions. The objective is to minimise overall delay, reduce costs and limit environmental impact while maintaining network stability.

The concept was tested through shadow and live validation exercises:

- **Shadow mode trials between Copenhagen Airport** and Brussels Airport, simulating capacity constraints at Brussels and assessing whether direct airport coordination could resolve issues more efficiently than traditional regulations.
- **Shadow mode and live trials between Athens International Airport** and Rhodes International Airport, using real and generated flight data to manage traffic during busy periods. Selected flights were assigned optimised arrival times to ease pressure on Rhodes.

Initial results indicate that more selective flight management can reduce delays compared to conventional ATFCM processes.

In parallel, Athens airport also served as a testbed for AI-powered taxi-time predictions, using machine learning to more accurately estimate when aircraft will be ready for departure or at gate upon arrival — further strengthening both local and network flow planning.

Predicting demand earlier and more accurately

While Solution 346 improves day-of-operations coordination, Solution 347 enhances planning in the strategic and pre-tactical phases.

The solution validates a data-driven approach to predict demand on airport resources — such as security lanes, baggage systems or border control — both locally and across the network. Using historic operational data from



FASTNet partners, machine-learning models have been developed to forecast:

- Passengers per flight
- Passenger presentation profiles at check-in, security and border control
- Number of hold baggage items per flight
- Number and impact of flow management regulations affecting an airport
- Early flight intentions from airlines to improve network traffic predictions

By reinforcing early information sharing between airports, airlines and the Network Manager — including extending Pre-Departure Information messages up to six days before operations — stakeholders gain better visibility and can plan tactical operations more effectively. Live validation exercises took place at Paris Orly Airport, with the participation of airport operations and IT teams, APOC staff, industry partner Indra, and airlines including Air France and Transavia. The connection to the network level was ensured via EUROCONTROL's Network Manager Validation Platform.

These trials followed passive and active shadow mode exercises, culminating in live operational use of FASTNet predictions.

Next steps: sharing the results

FASTNet will present the outcomes of its validation exercises at an open event hosted by Athens airport on 25 February 2026.

By demonstrating the combined value of real-time coordination and predictive analytics, FASTNet contributes to the evolution of air traffic management under Europe's Digital European Sky initiative. The lessons learned will feed directly into SESAR's innovation pipeline, paving the way for more resilient, efficient and sustainable airport and network operations.

What is FASTNET?

FASTNET - FASTNET- FUTURE DATA SERVICES AND APPLICATIONS FOR AIRPORTS AND NETWORK

Every flight begins and ends at airports, which makes them essential nodes in the aviation network. The project will make use of advances in data technologies to help fully integrate airport operations into the network (AOP-NOP integration). The project will focus on the pre-tactical and strategic planning, using artificial intelligence to enable airport-to-airport collaborative planning within the network operations plan. The project also aims to extend the timeframe of the AOP-NOP integration, from months to days in advance of departure. The project will rely on state-of-the-art technologies to integrate new datasets available at local level, such as local restrictions, pre-tactical flight information and strategic local information in order to enrich demand and capacity balancing information and ensure efficient planning from the strategic phase.

FASTNet solution 1 introduces the collaboration and coordination between airports directly, in the tactical phase of operations, ensuring an optimal traffic demand and capacity balancing prior to coordination with the Network Manager. The aim is to ensure that airport pairs (origin-destination airports) play an active role in the overall Air Traffic Flow and Capacity Management (ATFCM) process.

FASTNet Solution 2 reinforces the information sharing between airports and the Network Manager in the strategic and pre-tactical phase of operations. The aim is to ensure that the right information is shared as early as possible between the key stakeholders to ensure that tactical operations have been planned in an optimal way.

The proposed FASTNet solutions are expected to:

- Increase predictability on airport resources (Airport operators, ground handlers, etc),
- Maximise utilisation of available capacity at ground and airspace operations.
- Reduce ATFM delays to the benefit of ANSPs, Network Manager, Airspace Users and passengers. In addition, the prediction of regulations with their likelihood and possible quantification in delays will also provide clear benefits to airspace users.
- Improve the Network Demand and Capacity Balancing process, through the reinforced integration of Airports within the Network, by adjusting the Network capacity to airspace users' needs.
- Contribute to a lower environmental footprint, since a more predictable and punctual operation is directly linked with lower fuel consumption

Find more information at <https://www.sesarju.eu/projects/FASTnet>



The source is <https://www.sesarju.eu/news/fastnet-developing-data-driven-solutions-air-traffic-management>

Celebrating 50 Years of Innovation: ESA's Florence Congress Marks a Milestone

A Review of the “50 Years of Innovation in ESA” Congress and Its Impact on European Space Activities



From 20 to 22 May 2025, Florence played host to the landmark congress “50 Years of Innovation in ESA”, commemorating half a century of pioneering achievements by the European Space Agency (ESA) and its Basic Activities Programmes. The event served not only as a tribute to ESA's remarkable legacy but also as a platform for strategic dialogue among ESA, national delegations, and industry leaders ahead of the forthcoming Ministerial Council, scheduled for Bremen on 26 and 27 November 2025, resulted in a historic result, with an unprecedented budget allocation of €22.3 billion, signalling strong commitment to strength Europe leadership in space.

The Venue: Bridging Heritage and Innovation

The congress was held at Nana Bianca, a renowned startup studio, incubator, and accelerator, situated in the Granaio dell'Abbondanza—the historic Medici family granary dating back to the 17th century in Florence's Oltrarno district. This venue, now a modern innovation hub, provided a unique setting that seamlessly blended historical grandeur with contemporary technology, fostering both networking and inspiration in the heart of the city renowned for birthing the Renaissance. cally demanding sectors require careful consideration during regulatory development.

Participation and Atmosphere

More than 250 attendees participated, representing a cross-section of the European space sector. ESA's top management was present, including Director Dietmar Pilz (Director of Technology, Engineering and Quality Directorate at ESA), Franco Ongaro (former (Director of Technology, Engineering and Quality Directorate at ESA), and several heads of department. The Italian Space Agency (ASI) co-hosted the event, and representatives from around 15 Delegations of ESA Member States, leading space industries, academia, and students joined the gathering. The congress was conceived as an informal yet impactful forum, inviting all major space actors to

engage in open, fruitful dialogue—where past achievements, ongoing projects, and future plans met in a collaborative spirit to shape ESA's vision and the upcoming ministerial agenda.

Three Days, Three Perspectives: Past, Present, and Future

• DAY ONE: Honouring the Past

The opening day was dedicated to ESA's rich history in research and development. After welcoming remarks from Dietmar Pilz, Florence cabinet member Laura Sparavigna, and Fabrizio Battazza (Head of Relations with ESA Office), a panel featuring Eike Kircher (Head of Technology Programmes Office at ESA), Heinz Stoewer (Former Head of System Engineering Department at ESA), and Franco Ongaro recounted the evolution of R&D at ESA, sharing anecdotes that underscored the agency's ingenuity and resilience.

Most successful project managers—including Giuseppe Sarri (JUICE and Gaia), Albert Haldemann (Mars Chief Engineer), Giuseppe Mandorlo (Vigil), and Filippo Marliani (PLATO and LISA)—captivated the audience with insights on mission milestones and the critical role of technology preparation. These presentations were followed by a panel discussion chaired by Giovanni Colangelo (ESA Inspector General), featuring ESA managers, Wolfgang Pitz (CEO of Spacetech), and Enrico Suetta (Leonardo Space Division), focusing on lessons learned, R&D best practices, and avenues for future improvement.

The day concluded with a technical presentation by Marcos Bavdaz on Silicon Pore Optics technology, and forward-looking talks from Leopold Summerer (Head of Technology Department at ESA) and Giorgio Saccoccia (Senior Advisor at ESA), envisioning the next fifty years of ESA's Basic Activities. Massimo Comparini (Managing Director of Leonardo's Space Division) offered final reflections, followed by a cultural excursion to Museo Leonardiano in Vinci and a gala dinner at Le Fornaci di Sammontana, blending science with Italian heritage.

• DAY TWO: The Present and Path to the Ministerial

The second day shifted focus to current challenges and opportunities, particularly in the context of the upcoming Ministerial Council and the status of European space technology. Michelangelo Vasta (Professor, University of Siena) delivered a keynote address on "Technology and Economic Growth: From the Age of AI Back to the Renaissance," illustrating how R&D has historically driven prosperity and innovation, and drawing parallels between Europe's historical leadership and its contemporary decline, with Florence's Renaissance legacy serving as a poignant backdrop.

ESA speakers, national delegates, and industry representatives shared achievements, experiences, and their collective vision for the future. The day's discussions highlighted the pivotal role of the General Support Technology Programme (GSTP) in supporting technology investments and fostering European competitiveness. The closing panel, "Fast Innovation – R&D Outside ESA," featured engineers from the America's Cup boat design team and a developer of professional drones, offering comparative perspectives on innovation processes beyond the space sector. This cross-disciplinary dialogue illuminated fresh approaches to R&D, problem-solving, and technology transfer.

The evening's activities included a walking tour of Florence's city centre and a dinner hosted by Leonardo at Obicá, reinforcing the event's emphasis on informal networking and cultural exchange.

• DAY THREE: Looking Ahead

The final day was dedicated to future prospects, opening with pitches from startups and SMEs, sharing lessons learned and reflecting on how ESA's support has facilitated their growth. Discussions explored ways to enhance ESA's engagement with emerging companies, ensuring that the agency remains at the forefront of nurturing innovation. The day concluded with a stimulating debate on Europe's technological non-dependence and sovereignty, followed by a panel on ESA's Harmonisation activities, underscoring the importance of coordinated efforts in maintaining strategic autonomy and fostering collaboration across the continent.

Impact and Outlook

The Florence congress highlighted the transformative role of ESA's Discovery, Preparation, and Technology Development Element (TDE) programmes in shaping the success of Europe's flagship space missions. As discussed during the first day, these programmes have been instrumental in preparing the technological foundation for landmark projects, enabling breakthrough advances such as Silicon Pore Optics and other cutting-edge innovations. By fostering early-stage research, mission concept studies, and targeted technology development, Discovery, Preparation, and TDE have provided the essential groundwork that allows flagship missions to flourish and deliver ambitious scientific and technical outcomes.

On the third day, the congress celebrated the ripple effects of these initiatives on the broader technology ecosystem, recognising how their support has empowered European companies—from established industry giants to dynamic startups and SMEs—to lead in global innovation. ESA's mandatory budget funding ensures that

Impressions of the ESA's Florence Congress



the best ideas and technologies from all member states and industry sectors are harnessed, creating a vibrant and competitive environment that drives excellence. Success stories shared by startups demonstrated how ESA's engagement through Discovery, Preparation, and TDE has accelerated growth, opened new markets, and enabled companies to deliver high-impact solutions for space and beyond.

Showcasing these achievements was a central purpose of the workshop, underscoring the value of preparing future missions, advancing new technologies, and investing in innovation across Europe. The collaborative and inclusive approach—leveraging the mandatory budget to capture the brightest ideas from every corner of industry—has cemented Europe's leadership and technological independence in space. As ESA charts its path forward, the congress reaffirmed that Discovery, Preparation, and TDE are not only the bedrock of flagship mission success but also the driving force behind the continent's thriving space sector and its ongoing pursuit of excellence.

The Florence congress exemplified the spirit of collaboration and forward-thinking that has defined ESA's journey over the past five decades. By blending historical reflection with current analysis and future vision, the event not only celebrated ESA's achievements but also set the stage for the most ambitious Ministerial Council in its history, with a unprecedented budget allocation, the discussions around R&D best practices, and the focus on technology non-dependence all signal an era of renewed commitment to European excellence in space. As ESA embarks on its next fifty years, the lessons and relationships forged in Florence will serve as a foundation for innovation, resilience, and strategic leadership. The congress reaffirmed the importance of basic activities and R&D as the bedrock of space exploration, and highlighted the agency's unique ability to unite nations, industries, and academia in pursuit of shared goals.

50 Years of Innovation: ESA's Florence Congress main takeaway

- Marked fifty years of ESA innovation, fostering stronger strategic partnerships between ESA, Member States, industry, and academia ahead of the 2025 Ministerial Council.
- Emphasised the pivotal contribution of Discovery, Preparation, and TDE programmes to Europe's leading space missions.
- Introduced fresh perspectives on innovation through engagement with high-performing sectors beyond the space industry.
- Highlighted the increasing influence of SMEs and startups benefitting from ESA support.
- Helped shape a unified vision, paving the way for the record €22.3 billion budget approved in Bremen.
- Strengthened Europe's dedication to technological sovereignty and enduring space leadership.
- Gathered over 250 participants from ESA, national delegations, space industry, and academic institutions.
- Provided ample opportunities for networking and informal discussions over the three-day event.
- Facilitated meaningful knowledge exchange regarding ESA R&D programmes, future plans, and collaboration avenues with industry and academia.
- Enriched attendees with cultural experiences, exploring Florence's Renaissance heritage.

How Sector-Agnostic Regulations Affect the European Space Supply Chain

By Mr. Premysl JANIK, REACH Officer & Chairman of MPTB (Materials and Processes Technology Board) at ESA ESTEC

Introduction

Europe's space sector depends on highly specialised materials, components and chemical processes. These inputs enable spacecraft to operate reliably in extreme environments, yet they are increasingly affected by broad, sector-agnostic regulations intended to support environmental and sustainability goals. Over the past decades, Europe has shifted much of its chemical and material production capacity outside the region, relying more heavily on global supply chains. This trend coincides with expanding EU regulatory frameworks, which place additional responsibilities on companies at every stage of design, qualification and manufacturing.

The question facing the sector is how to maintain safe and secure access to space while navigating complex and evolving legislation. This article provides a concise and neutral overview of the regulatory landscape and uses **PFAS** (Per- and Polyfluoroalkyl Substances) as a representative example of substances whose **EU REACH** restriction, as it is presently proposed, would pose major challenges for space technologies. The aim is to explain the issues in plain language and highlight why technically demanding sectors require careful consideration during regulatory development.

Regulatory Landscape

Since the introduction of the European Green Deal in 2019, the number of legal acts and proposals potentially affecting materials used in space applications has increased significantly. These include revisions to **CLP** and **REACH** (Commission proposal still pending), the Ecodesign for Sustainable Products Regulation (ESPR), and company-level sustainability rules such as CSRD, CSDDD and the EU Taxonomy. Additional frameworks address the sourcing of raw materials, waste and recycling, and reporting obligations. International agreements, such as the Stockholm Convention on persistent organic pollutants, also influence substance availability. External factors reinforce these challenges. Several countries have introduced export controls on materials essential to high-tech industries, including elements used in electronics, magnets and photovoltaics. For companies producing space hardware, these combined pressures create uncertainty around long-term material availability, qualification stability and supply-chain resilience. Holistic overview of the various limitations, requirements and constraints are displayed on the *Figure 1*.

Figure 1. Schematic overview of relevant legislation and other constraints



Rising Complexity for Industry

Most of the new or revised regulations are sector-agnostic. They apply equally to consumer goods, large-scale manufacturing, automotive supply chains and niche industries such as space. Because many provisions were designed independently, companies often face overlapping requirements that do not fully reflect practical or technical limits. SMEs entering the market today must evaluate environmental, social and reporting obligations alongside strict reliability and safety standards. Underestimating compliance costs or overlooking a relevant provision may significantly affect project viability.

Some regulations require public disclosure of supply-chain information. While transparency is valuable for consumer products, sensitive details about materials used in spacecraft, launchers or high-performance components may unintentionally disadvantage companies working with critical or security-relevant technologies. For this reason, proportionality and sector-specific needs should be considered when designing reporting obligations. Because some regulatory provisions are often contradicting each other, plus there are also very demanding technical requirements, this leaves industry with narrowing solutions (see Figure 2).

Figure 2. Schematic showing narrowing intersection between technical and regulatory requirements.

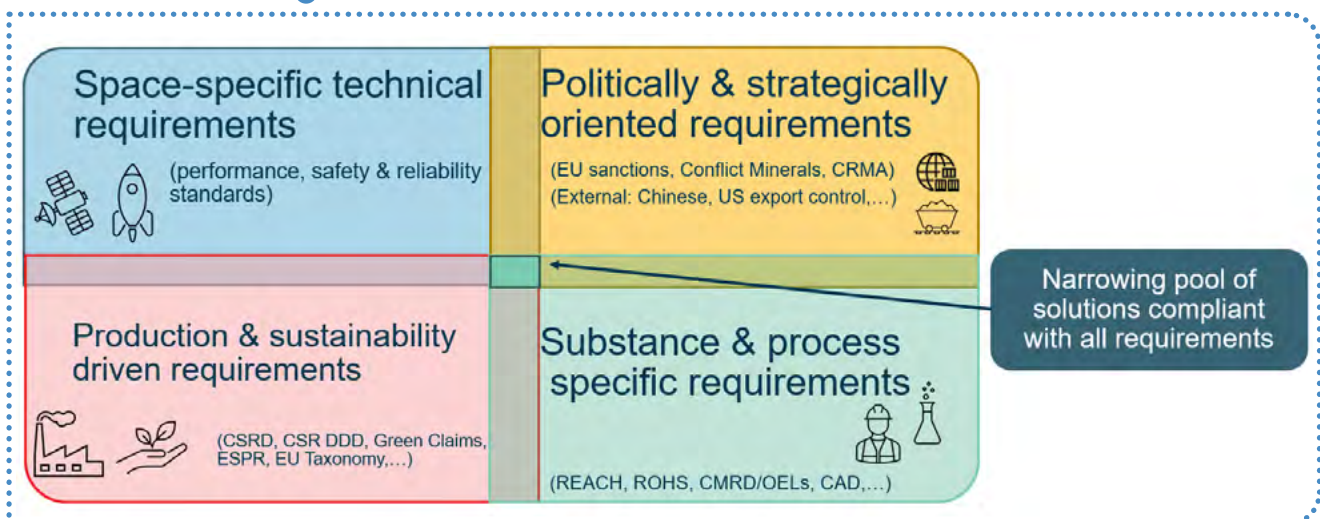

Substances of Highest Priority

Across Europe, the space sector monitors approximately 3,500 unique substances used in more than 1,250 materials and mixtures. Only a subset is strategically critical, but many are undergoing regulatory scrutiny. Prioritisation is therefore essential. Based on frequency of use, lack of alternatives and technical relevance, the sector has identified several high-priority groups: PFAS, hydrazine and other energetic materials, hexavalent chromium (including chromium trioxide), certain solvents

classified as CMR (cancerogenic, mutagenic and reprotoxic), metallic lead, bisphenol-based chemistries, cyclic siloxanes, diisocyanates and microplastics.

These substances support space mission-critical functions such as corrosion resistance, bonding, dielectric stability, thermal management, chemical inertness and contamination control. Even when quantities used are small, removing or reformulating them may require re-designing hardware that has accumulated decades of flight heritage. Alternatives developed for other industries typically do not offer the same performance in vacuum, radiation or extreme temperature conditions. For this reason, a material can only be considered a true replacement once it has been tested, qualified and demonstrated in successful flight (= maximum technology readiness level).

Challenges of Phasing Out Materials

The concept of "regrettable substitution" is often cited when alternatives introduce similar hazards to the substances they replace. In the space sector, substitution also carries a high risk of unintended technical or programmatic impacts. Because material volumes are extremely small, the environmental benefit of substitution may be limited, yet the effort required for requalification is substantial. Testing new materials, updating specifications and validating manufacturing processes can take years and may delay missions already in development.

Companies may also face environmental burdens linked to repeated requalification campaigns, which require energy, test equipment and laboratory work. Uncertainty around future regulations reduces incentives for European companies to invest in new materials or chemistries, further limiting the availability of high-performance alternatives produced within Europe. Over time, this dynamic contributes to shrinking material portfolios and greater reliance on external suppliers.

PFAS as an Illustrative Case

The proposed universal PFAS (uPFAS) restriction under REACH has become one of the most significant regulatory drivers affecting space materials. The definition covers a very broad structural class, meaning thousands of fluorinated substances could fall within scope. Many of these play essential roles in space hardware due to their thermal stability, low outgassing, moisture resistance, dielectric properties and chemical inertness. More information on how problematic the elimination of PFAS is for the space sector can be found in Sectoral response paper **ASD-Eurospace**¹.

A schematic overview of PFAS uses in the Ariane 6 launcher (Figure 3) demonstrates that most subsystems rely on one or more fluorinated materials. Similar patterns appear in spacecraft.

For example, an Earth-observation satellite (Figure 4) with approximately 2,700 declared material items may include PFAS in around 10% of entries. Although the mass fraction is small, the functional significance is high. PFAS are present in electrical harnesses, composite interfaces, tank liners, membranes, optical coatings, gaskets, seals, lubricants and high-reliability electronic components.

Reduced Availability and Supply-Chain Effects

Even before restrictions are adopted, regulatory uncertainty influences industry behaviour. Some manufacturers have announced discontinuation of PFAS-containing products or precursors, including surfactants used to produce fluoropolymers. In certain cases, the phase-out extends to the fluoropolymers themselves. As production declines, companies may face higher prices, longer

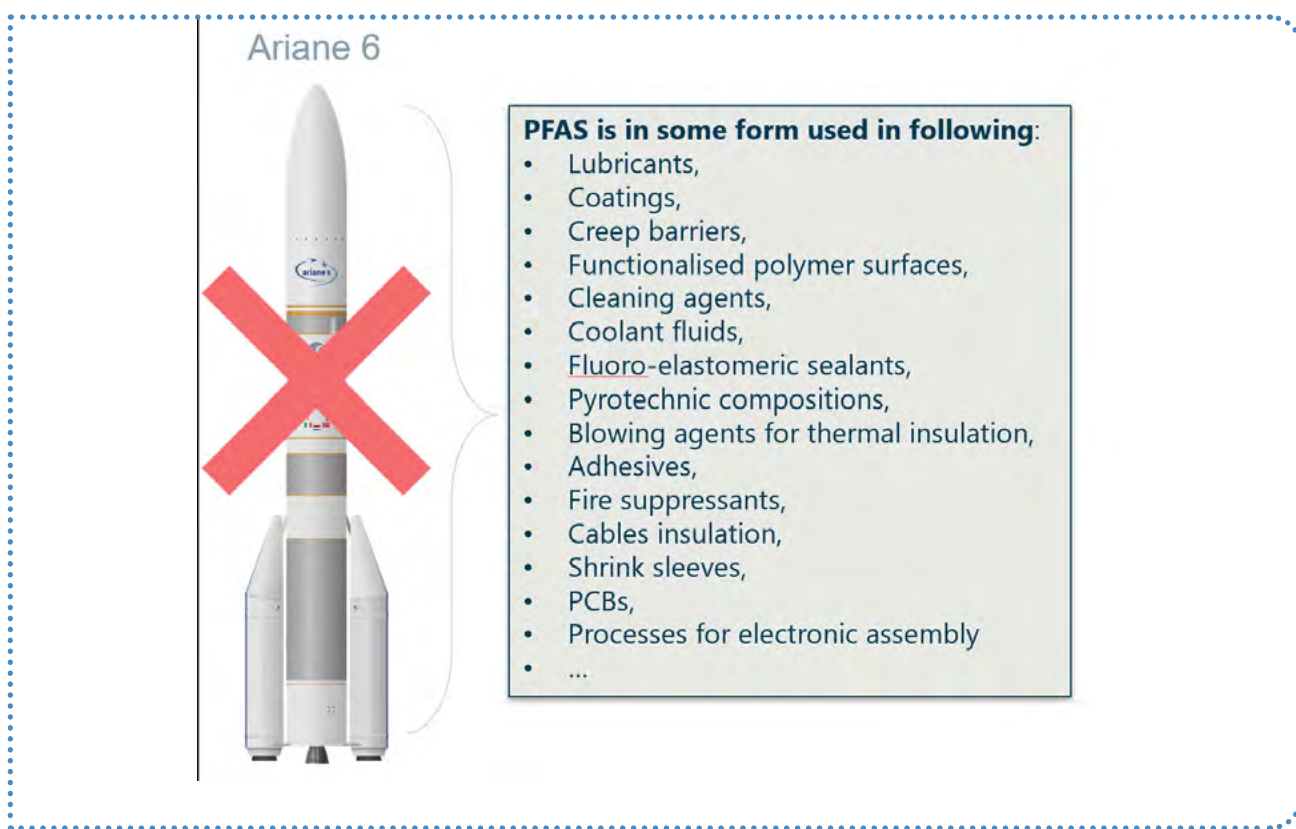

Figure 3. Ariane 6 with list of most profound PFAS uses in the launcher (not exhaustive)

Exemplar spacecraft



Where are PFAS used in spacecraft?:

outer thermal insulation, printed circuit boards, lubricants, cables, connectors, gaskets, tubes, ...

> 10% of all declared material items in average are or contain PFAS (tens of kilograms per spacecraft at maximum, compared to millions of tonnes for other sectors)

Figure 4: Representation of Earth Observation satellite with qualitative analysis of PFAS, essential for functionality of its systems

lead times or reformulated materials that require new qualification. For high-reliability components, even minor changes may affect performance, leading to additional verification and validation work.

Because space missions depend on long-term stability of material specifications, unexpected changes can disrupt programme schedules and budgets. A single unavailable component may delay a spacecraft or launcher that took years to design. The cost of requalification or redesign may be disproportionate compared with the environmental or health impact associated with the very small quantities used in space applications. Wide reaching impact is also visualised in the *Figure 5*.

Sector Coordination and Mitigation

To support early detection of regulatory risks, ESA, national space agencies and industrial partners coordinate through the Materials and Processes Technology Board (MPTB) under ESCC initiative. This Board brings together technical specialists, national agencies and regulatory experts to analyse upcoming restrictions and consolidate sector-wide feedback. A dedicated Restriction Task Force (RTF) focuses on REACH activities, including the uPFAS restriction proposal. ESA also provides REACH workshops², webinars³, guidance and a digital tool (ESA REACH Tool⁴) for tracking material availability and regulatory

status, which is accessible to organisations participating in European space programmes.

By combining technical and regulatory expertise, these groups help identify potential issues early and support proportionate implementation of new legal requirements.

Improving Regulatory Processes

The universal PFAS restriction proposal highlights the importance of early engagement between regulators and specialised sectors. Some materials perform functions that cannot currently be replicated with non-fluorinated alternatives. When broad restrictions are considered, it is therefore essential to assess technical feasibility, long-term programme impact and strategic relevance. Early dialogue during the intention phase of restrictions would allow sectors such as space to provide evidence BEFORE regulatory proposals are finalised.

Mechanisms for addressing conflicts between sector-agnostic regulations and essential capabilities would also be beneficial. This may involve assessing strategic impacts related to safety, security, navigation, observation and scientific missions. Coordinated discussion among the European Commission, Member States, ESA and industry could help ensure that new regulatory measures remain proportionate and aligned with Europe's broader objectives and will not unintentionally impact niche sectors such as space.

1. European Space Sector comments on the Annex XV restriction report for per- and polyfluoroalkyl substances (PFAS) of 22 September 2023, <https://eurospace.org/download/5515/?tmstv=1695629365>

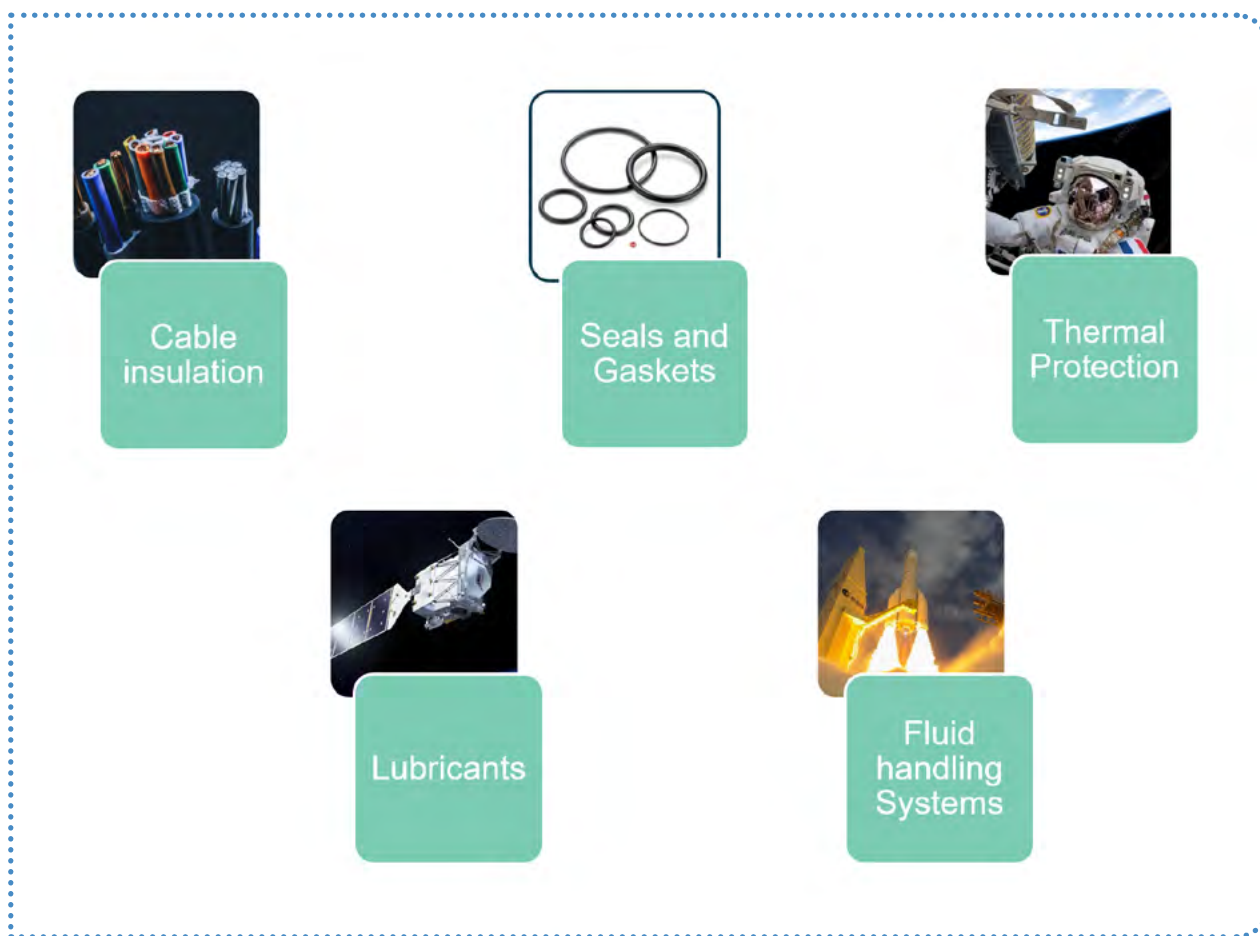

Figure 5. Schematic list of some of the impacted materials essential for the space sector

Conclusions

The European space sector already operates within one of the most demanding technical and regulatory environments. While environmental and sustainability goals are important, broad restrictions that do not account for sector-specific needs may affect Europe's capacity to design, manufacture and operate space systems. PFAS offer a clear example: these materials are used in many mission-critical applications, yet suitable alternatives are often not available and, in some cases, not available at all.

Strengthening early-stage impact assessment, enhancing coordination among regulatory and technical bodies, and maintaining dialogue with specialised industries will help ensure that Europe meets environmental objectives while preserving safe and reliable access to space. A balanced approach supports both sustainability and long-term strategic autonomy.

2. Summary from 6th Workshop edition in 2025 available online: <https://atpi.eventsair.com/6th-esa-reach-workshop>
3. Info about webinars will be available on <https://learninghub.esa.int/>
4. ESA REACH Tool accessible online: <https://reachtool.esa.int/About>

Product Assurance: The Silent Force Behind Copernicus Mission Success



ESA's Product Assurance teams ensure every Copernicus satellite delivers on its promise to our planet."



Figure 1 MetOP-SG A1&B1 with Sentinel-5 at Airbus in Toulouse (Credits: ESA - M. Pédoussaut)

Copernicus – the Earth observation component of the European Union's Space programme – represents a major advance in climate science, disaster response, and global safety. The Sentinel satellites and instruments underpinning the Copernicus missions are not only technological marvels, but also a result of global cooperation. Remarkably, 2025 saw no less than four different missions launched.

From the lush forests of French Guiana, where Ariane 62 thundered skyward with the Sentinel-5A spectrometer (hosted on the Metop-SG-A1 satellite) in August and with the Sentinel-1D satellite in November, to the rugged California coast at Vandenberg, where Falcon 9 propelled Sentinel-6B into orbit in November, and to the historic pads of Cape Canaveral, where the Sentinel-4A spectrometer (hosted on MTG-S) began its journey in July, each launch is a testament to international collaboration and engineering excellence.

Behind every successful liftoff and every stream of vital Earth observation data lies a silent force: Product Assu-

rance. Product Assurance is the invisible shield that ensures every Sentinel mission delivers on its promise, no matter the rocket, launch site, or mission complexity. It's the discipline that transforms fragile prototypes into reliable spacecraft that help safeguard the future of our planet.

Space is unforgiving. A single flaw, whether in a sensor, a bolt or a line of code, can mean the loss of hundreds of millions of euros, missed scientific breakthroughs, or delayed disaster warnings. For Copernicus, the stakes are even higher: these satellites are Earth's eyes, monitoring everything from air quality to sea-level rise.

Product Assurance is the discipline that makes Copernicus satellites and instruments reliable, regardless of the type of mission or launcher. From the smallest sensor to the largest ground station, Product Assurance ensures that every component and procedure meets ESA's uncompromising standards for quality and safety.

Product Assurance is the discipline that quietly underpins every ESA mission, ensuring that each satellite,



Figure 2 MTG-S and Sentinel-4 in the cleanroom
(Credits: ESA - M. Pédoussaut)

whether Sentinel-1D, Sentinel-4, Sentinel-5 or Sentinel-6B, is built to thrive in the harsh environment of space. At its core, Product Assurance is a culture of vigilance and excellence, driven by professionals whose expertise and judgment are as vital as any technology. Product Assurance teams anticipate problems before they arise, trace the origin and history of every component, and rigorously verify that every system performs as intended, no matter the launch vehicle or the destination orbit.

Product Assurance doesn't stop at the edge of space, it extends to the ground systems that keep Sentinel missions running. At the European Space Operations Centre (ESOC) during critical operational phases such as the launch and the Launch and Early Orbit Phase, the presence of Product Assurance in the Main Control Room is pivotal.

Product Assurance validates procedures and tools, ensures configuration integrity across shifts, and confirms



Figure 3 Sentinel-1D encapsulation (credits: ESA - M. Pédoussaut)



Figure 4 Sentinel-1D launch (credits: ESA - S. Corvaja)

that all teams operate from a controlled baseline. This oversight reinforces stakeholder trust by demonstrating that risks are understood, processes are controlled, and decisions are traceable. Even after launch, Product Assurance continues to safeguard mission performance by maintaining validated operational products, supporting anomaly assessments, and ensuring a clean transition to routine operations. As demonstrated in missions like

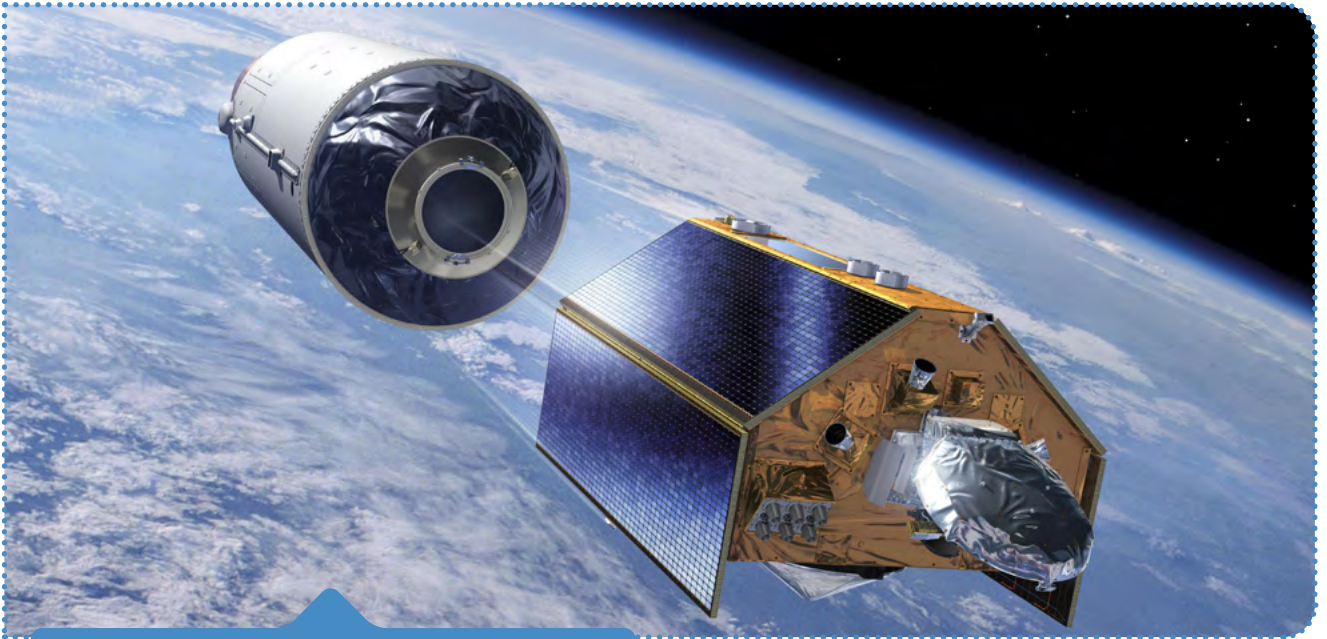

Figure 5 Artist's view of Sentinel-6B being released from its Falcon 9 launcher (Credits: ESA - D. Ducros)

Sentinel-1D and Sentinel-6B, this role is crucial in guaranteeing operational readiness, documentation integrity, and the mitigation of risks throughout the mission lifecycle. This vigilance guarantees that the vital information collected by the Sentinels is delivered accurately and securely, supporting climate science and disaster response around the globe.

When unexpected challenges arise, Product Assurance's rapid troubleshooting turns lessons learned from previous launches into smarter solutions for the future. This agility means Copernicus missions can push boundaries while maintaining the highest standards of reliability and safety.

"Product Assurance, in support of ESA's Earth Observation Framework – Copernicus Space Component, coordinates the configuration, anomaly and maintenance management of a complex operational machine. Dozens of services providers, for example, for mission planning, acquisition, processing, archiving and distribution, raise anomaly reports, trigger changes to keep up with technology innovation, have to serve increasingly demanding user requests, all with the objective of providing Copernicus users with the best up-to-date Earth observation data. Ensuring the quality of these tangled processes is no mean feat," says the Product Assurance Manager for Copernicus Mission Management and Operations at the European Space Research Institute (ESRIN).

Behind every Sentinel launch is a team of Product Assurance engineers whose expertise and mindset make all the difference. Their work is often invisible, if everything goes right, few will ever know the challenges they had to overcome.

“Product Assurance engineers approach each mission with healthy scepticism and relentless curiosity, always asking “what if?” and “how can we do better?” They take pride in the quiet success of a flawless launch, knowing their attention to detail has safeguarded the mission.

As Sentinel-1 Product Assurance and Safety Manager shared, “Engineering is the art of making it work. Product Assurance is the science of making it work when failure is not an option.”

Whether collaborating in cleanrooms, reviewing test results late into the night, or leading safety briefings before launch, these professionals are the silent guardians of Copernicus. Every Sentinel satellite and instrument begins at the European Space Research and Technology Centre (ESTEC) as a vision, shaped by engineers and scientists, but it's through the relentless work of Product Assurance that these visions become reality. Product Assurance guides each mission through countless design reviews, rigorous testing and meticulous documentation, ensuring that every component and system can withstand the extremes of launch and the unforgiving environment of space. From the first sketch to the final countdown, Product Assurance weaves reliability into the very fabric of each satellite. It's the unseen force that anticipates problems, solves them before they arise, and guarantees that when a Sentinel satellite leaves Earth's surface, it's ready to deliver vital data for years to come. In this way, Product Assurance doesn't just safeguard hardware; it protects the future of our planet, enabling Copernicus missions to watch over Earth with unwavering trust.

Mission Objectives Recap

Copernicus Sentinel-1D

Works alongside Sentinel-1C to provide frequent, high-resolution radar imagery of Earth's surface using C-band synthetic aperture radar (SAR).

Supports ship detection and tracking with Automatic Identification System (AIS) instruments, enabling improved maritime surveillance.

Compatible with Galileo and other global navigation systems for enhanced geolocation accuracy.

Copernicus Sentinel-4

Delivers hourly measurements of air pollution across Europe with unprecedented detail and precision.

Embarked on the MTG-S weather satellite, Sentinel-4 transforms air-quality forecasting by monitoring trace gases and aerosols from geostationary orbit.

Copernicus Sentinel-5

Introduces an advanced imaging spectrometer aboard MetOp-SG-A1, building on Sentinel-5 Precursor's legacy. Provides daily global data on key air pollutants, climate variables, and stratospheric ozone.

Measures a wide range of trace gases (ozone, nitrogen dioxide, sulphur dioxide, formaldehyde, glyoxal, carbon monoxide, methane) and aerosols, supporting climate research and air quality monitoring.

Copernicus Sentinel-6B

Serves as the world's reference mission for sea-surface height measurements, continuing the record begun by TOPEX-Poseidon and Jason satellites.

Maps sea-surface height, significant wave height, and wind speed for both long-term climate studies and real-time ocean forecasting.

Uses a radar altimeter and advanced microwave radiometer to deliver highly accurate ocean data, accounting for atmospheric water vapour effects.

Figure 6 S1D 360° photo of Sentinel-1D LEOP team
(credits: ESA – T. Ormston)



Outline of the latest issues of the **CEAS Aeronautical journal** and the **CEAS Space Journal**

The **CEAS Aeronautical Journal** and the **CEAS Space Journal** were created under the umbrella of CEAS to provide an appropriate platform for excellent scientific publications submitted by scientists and engineers. The German Aerospace Center (DLR) and the European Space Agency (ESA) support the Journals, which are published by Springer Nature. Both Journals publish peer-reviewed original articles, review articles and short communications.

The **CEAS Aeronautical Journal** is dedicated to publishing results and findings in all areas of aeronautical science and technology as well as new developments in digital design and manufacturing of aircraft, rotorcraft, and unmanned aerial vehicles. A key aspect of growing importance is the mitigation of the aviation-related climate impact.

The **CEAS Space Journal** is devoted to excellent new developments and results in all areas of space-related science and technology, including important spin-off capabilities and applications as well as ground-based support systems and manufacturing advancements. Disciplines of interest include all those that reflect

consolidated and new technologies and requirements that stem from new applications of space assets. Both journals are indexed in Scopus and Web of Science. **We invite you and your colleagues to contribute to the further development of these journals by submitting the results of your excellent research for publication, as well as acting as reviewers. If you are interested in becoming an associate editor, please contact the relevant Managing Editor:**

• **For the CEAS Aeronautical Journal:**

cornelia.hillenherms@dlr.de;

<https://link.springer.com/journal/13272>;

• **For the CEAS Space Journal:**

andrea.dieball@dlr.de;

<https://link.springer.com/journal/12567>.

A list of articles published in the latest issues of both CEAS Journals is attached.

The Managing Editors:

- Andrea Dieball
- Cornelia Hillenherms
- Wilhelm Kordulla
- Janko Kreikemeier
- Johan Steelant

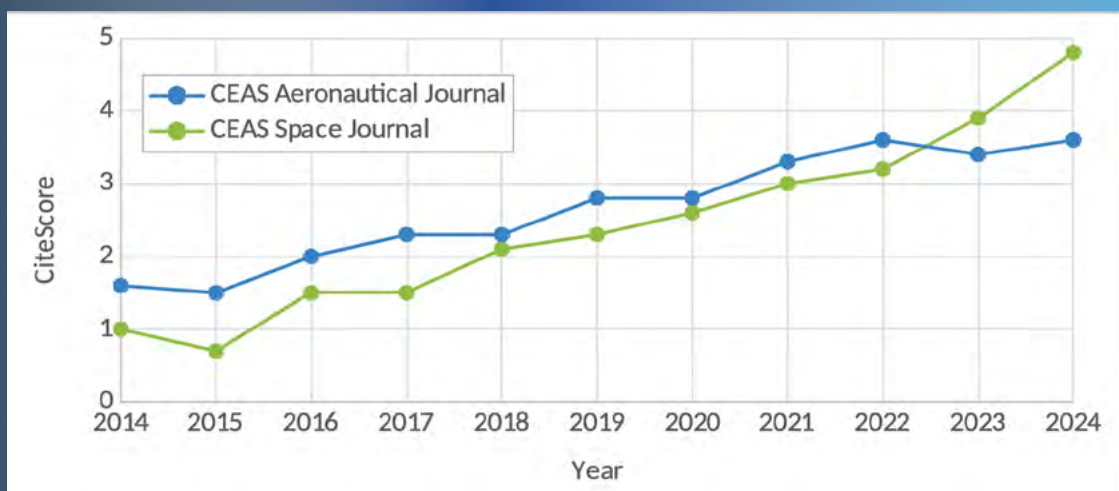

CiteScore: For a 4-year time span, the number of citations received for the publications in the same time span is divided by the number of publications in these years [Source: <https://www.scopus.com/>].

CEAS AERONAUTICAL JOURNAL



**Volume 17, Issue 1,
January 2026**

Thank you to our CEAS Aeronautical Journal Reviewers

- Editorial from the Managing Editors / *Published: 23 February 2026 (Open Access)*

CEAS Most Cited Paper Award

- Editorial from Markus Fischer, Cornelia Hillenherms, Andrea Dieball & Janko Kreikemeier / *Published: 23 February 2026 (Open Access)*

Scientific assessment for urban air mobility (UAM)

- Bianca I. Schuchardt, Adriana Andreeva-Mori, Parimal H. Kopardekar, Vadim Kramar, James Murphy, Mayara Condé Rocha Murça & David Sziroczák / *Published: 21 January 2026 (Open Access)*

Term	Description of Term
Advanced Air Mobility (AAM)	A transportation system that transports people and property by air between two points in the NAS using aircraft with advanced technologies, including electric aircraft or electric vertical take-off and landing aircraft, in both controlled and uncontrolled airspace
Air Metro	An UAM market that resembles current public transit options such as subways and buses, with predetermined routes, regular schedules, and set stops in high-traffic areas throughout each city
Air Taxi	An AAM market providing point-to-point passenger transportation and not operated on regular schedules or routes
Autonomy	The ability of a system to achieve goals while operating independently of external control. Autonomy requires self-directedness to achieve goals and self-sufficiency to operate independently

Industry 5.0 in aircraft production and MRO: challenges and opportunities

- Keno Moenck, Julian Koch, Jan-Erik Rath, Lukas Büsch, Johann Gierecker, Falko Kähler, Florian Kalscheuer, Christian Masuhr, Johann Kipping, Philipp Prünke, Daniel Schoepflin, Henrik Eschen, Lukas Antonio Wulff, Rebecca Rodeck, Gerko Wende, Martin Gomse & Thorsten Schüppstuhl / *Published: 05 April 2025 (Open Access)*



Workload considerations in simultaneous piloting of multiple RPA on agricultural spraying

- Matheus Coelho Gonçalves & Jorge Henrique Biddotto / *Published: 10 April 2025*

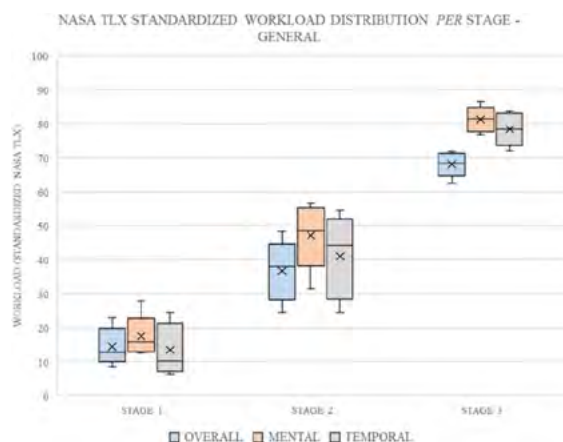

Conditional integrator sliding mode control to reduce susceptibility to pilot-induced oscillations

• Jose Junior Leão Rodrigues, Marcelo Santiago de Sousa, Yohan Ali Diaz Méndez & Sebastião Simões da Cunha Junior / *Published: 15 April 2025*

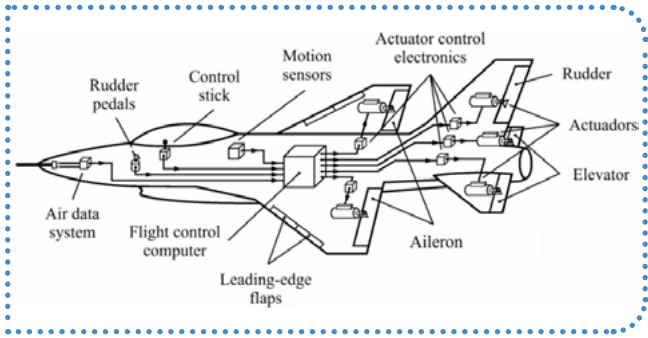

Airframe noise simulation of an A320 aircraft in landing configuration

• Stan Proskurov, Michael Moessner, Roland Ewert, Jan W. Delfs, Juergen Dierke, Michael Pott-Pollenske & Daniela Almoneit / *Published: 09 May 2025 (Open Access)*

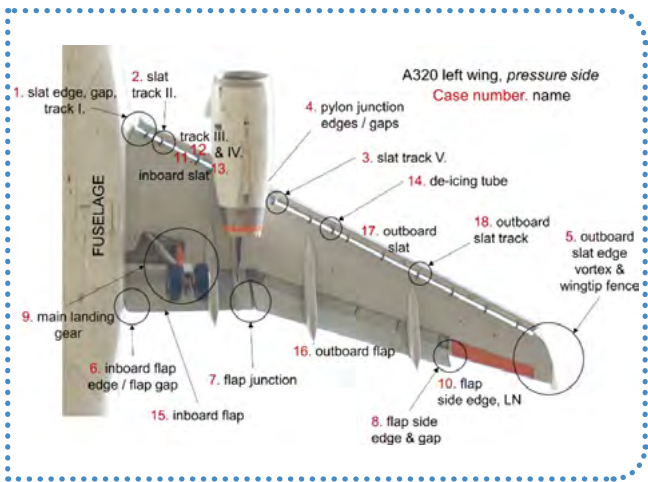

Agile, post-quantum secure cryptography in avionics

• Karolin Varner, Wanja Zaeske, Sven Friedrich, Aaron Kaiser & Alice Bowman / *Published 12 May 2025 (Open Access)*

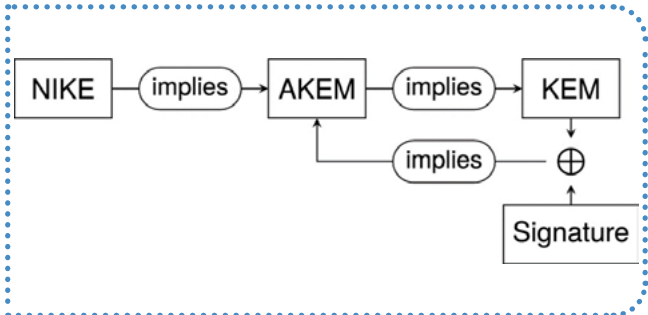

Sensitivity analysis of aerial wildfire fighting tactics with heterogeneous fleets using an agent-based simulation framework

• N. Cigal, N. Naeem, P. Ratei, S. Kilkis, P. S. Prakasha & B. Nagel / *Published: 13 May 2025 (Open Access)*

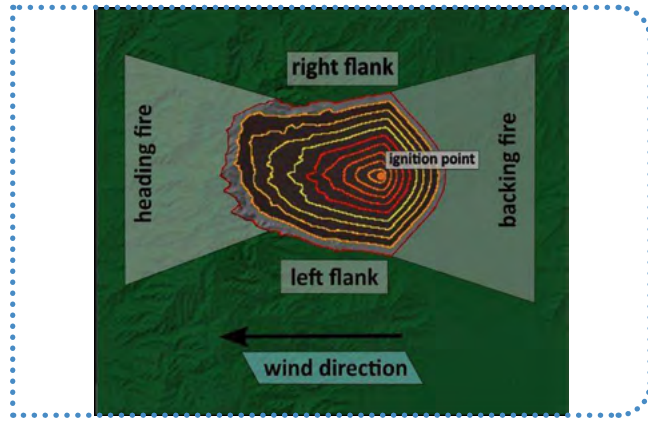

Implementation and validation of an optimization-based propeller design program

• M. Schmähl & M. Hornung / *Published: 16 May 2025 (Open Access)*

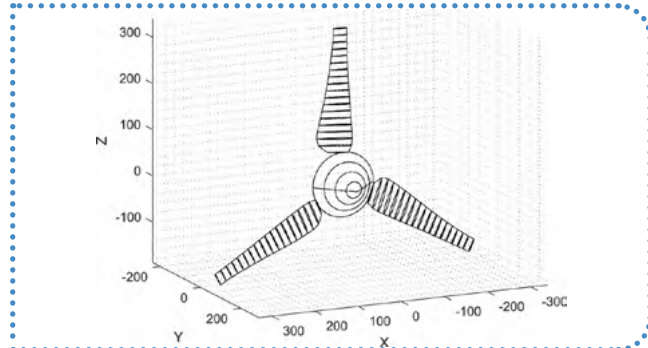

Improved configuration management for greener approaches: evaluation of a novel pilot support concept

• Tobias Bauer, Fethi Abdelmoula, Johan Boyer, Martin Gerber, Jonas Meister & Jean Marc Wunderli / *Published: 17 May 2025 (Open Access)*

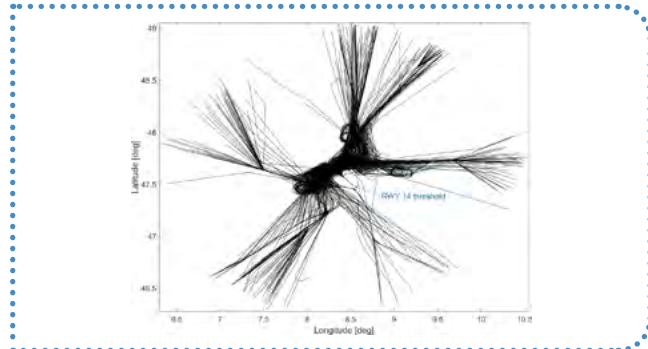

Experimental investigation of broadband noise generation of a small rotor in hover and forward flight

• Felix Lößle, Rainer Schmid, Anna A. Kostek, Daniel Ernst, Clemens Schwarz, Johannes N. Braukmann & C. Christian Wolf / *Published: 19 May 2025 (Open Access)*

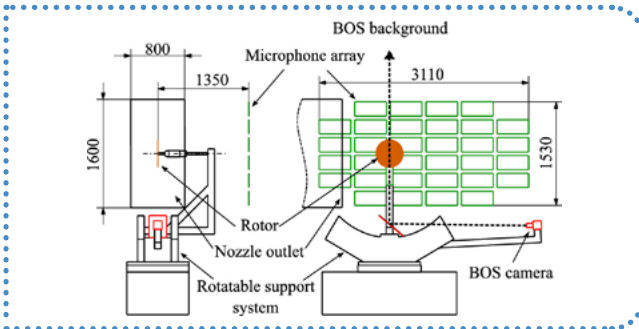

Reference tracking of nonlinear airborne systems using stochastic MPC with disturbance observers and actuator chance constraint optimization

• Suryansh Aryan / *Published: 26 May 2025 (Open Access)*

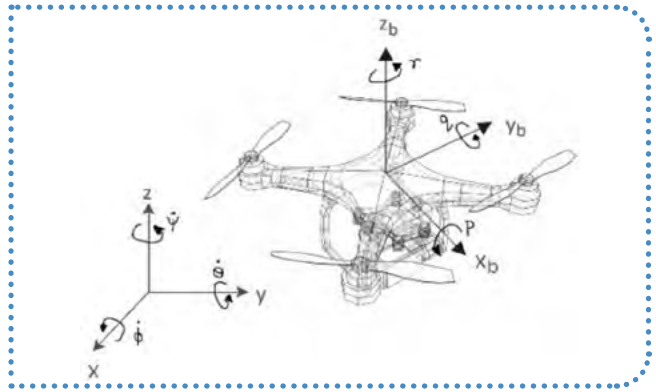

Long-term monitoring of barometric altitude measurement performance using the example of a research aircraft

• Carsten Christmann / *Published: 23 May 2025 (Open Access)*



Methodologies for the determination of aircraft stability of the standard dynamics model at extreme angles of attack

• L. K. Fitzgerald, P. C. Griffin & A. J. Niven / *Published: 26 May 2025 (Open Access)*



Modeling hailstone fragmentation upon impact with curved aircraft panels using a modified Hertzian contact mechanics framework

• Anand Pai, P. K. Sowmya, Khushhali Chaudhary, Chandrakant R. Kini, Suhas Yeshwant Nayak & B. Satish Shenoy / *Published: 25 May 2025 (Open Access)*

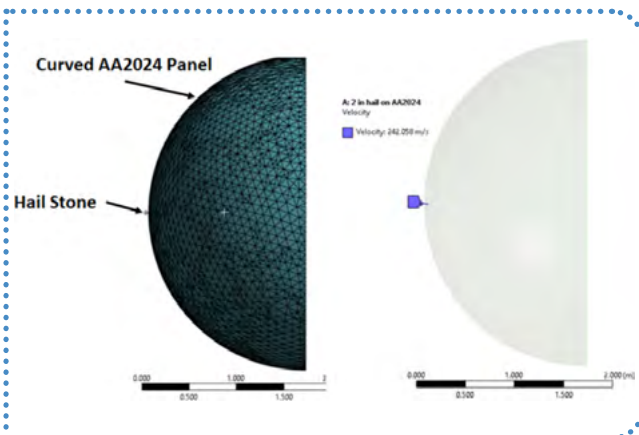

High-fidelity multidisciplinary maneuver simulations of the Falcon 2000LX ISTAR

• M. Bauer & J. Feldwisch / *Published: 03 June 2025 (Open Access)*

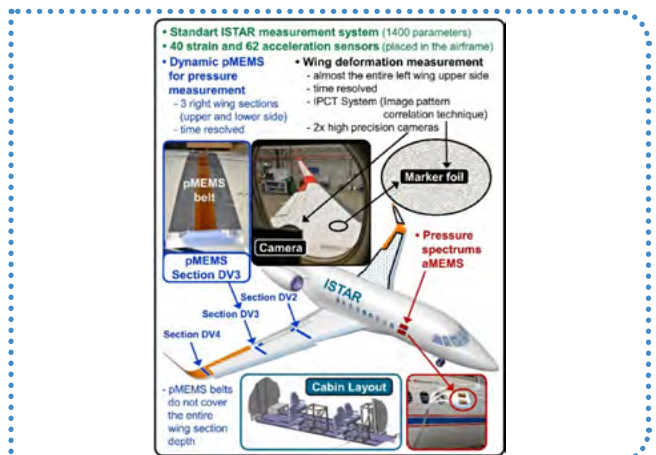

Predicting and reconstructing clearances from air traffic data using a supervised learning

• Justus Renkhoff, Niclas Wüstenbecker, Mohsan Jameel & Sebastian Schier-Morgenthal / *Published: 07 June 2025 (Open Access)*

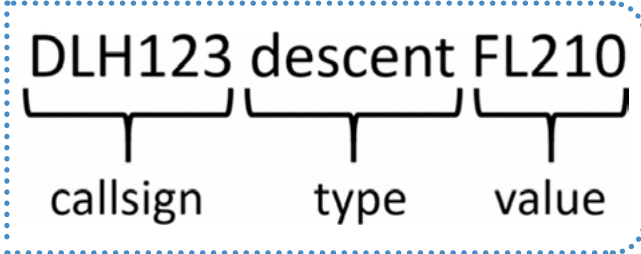

Advances on the integration of transport drones into offshore wind farms

• Alexander Donkels, Sebastian Cain, Jannik Wilhelm, John Dippmar, Detlef Heil, Jonas Janke & Tilmann Bruns / *Published: 09 June 2025 (Open Access)*

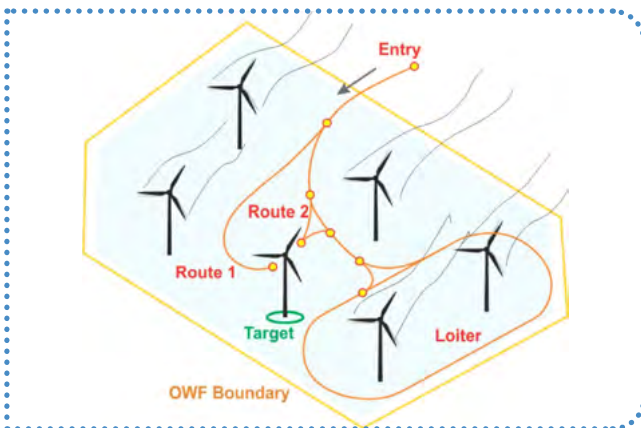

Integrating multilevel failure analysis with a systematic approach to functional safety requirements allocation in aviation systems

• Ammar Chakhrit, Nour EL Houda Benharkat & Islam H. M. Guetarni / *Published: 09 June 2025*

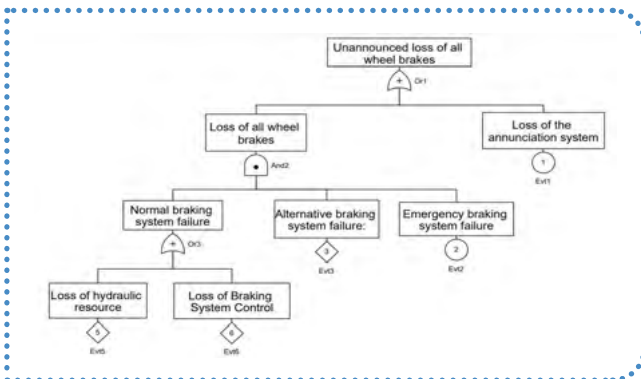

Multidisciplinary aeroelastic optimization of high aspect-ratio composite aircraft wings via tow-

• Nikolaos Ziakos, Spyridon Kilimtzidis & Vassilis Kostopoulos / *Published: 09 June 2025 (Open Access)*

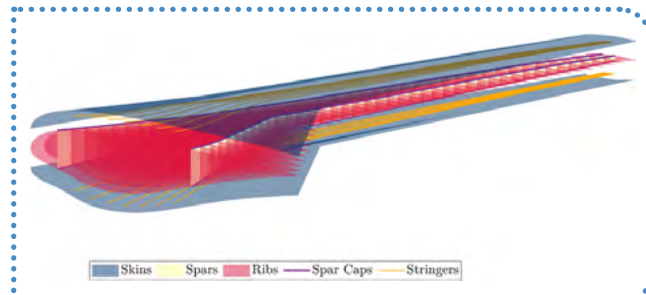

Manufacturing, modelling and testing of acoustic liners extended with flexible walls

• Fleming Kohlenberg, Moritz Neubauer, Julia Genßler, Vincent Radmann & Karsten Knobloch / *Published: 13 June 2025 (Open Access)*

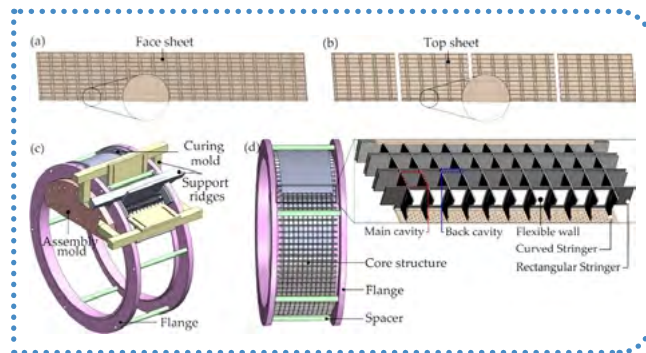

Transition prediction including turbulent wedges for a forward swept natural laminar flow wing

• Michael Fehrs & Christoph Kaiser / *Published: 16 June 2025 (Open Access)*

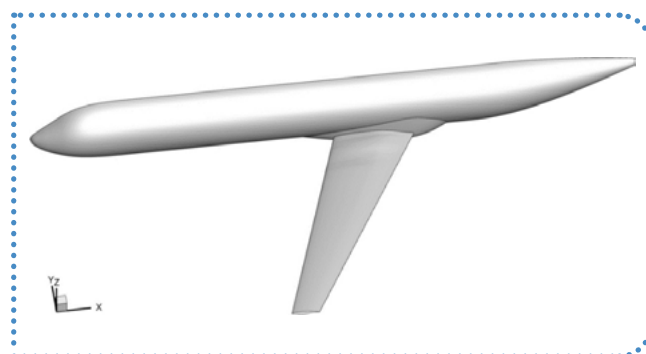

CEAS SPACE JOURNAL



**Volume 18, Issue 1,
January 2026**

Survey of high-voltage DC/DC converters for electro spray thrusters

• Francisco José Blázquez-Plaza, Andrés Barrado & Mick Wijnen / *Published online: 21 April 2025*

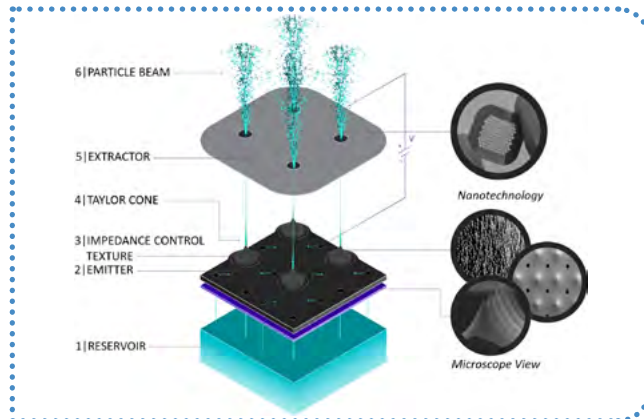

Mathematical analysis approach for the pre-design of landing platforms with alignment, leveling, and lowering function

• Jan Bertram & Lars Witte / *Published online: 23 April 2025 (Open Access)*

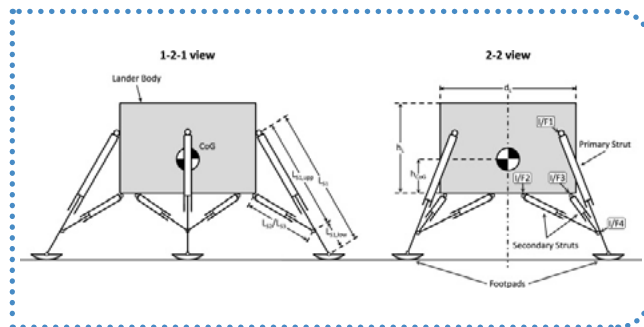

Implementation and characterization of a W-band SatCom ground terminal receiver with 5 GHz reception bandwidth and mechanical beam steering

• Laura Manoliu, Erfan Amini, Marcel Sauter, Dominik Wrana, Janis Wörmann, Simon Haussmann, Benjamin Schoch, Ralf Henneberger, Axel Tessmann, Hugh J. Gibson, Ivica Bozic, Markus T. Koller, Jens Freese & Ingmar Kallfas / *Published online: 29 April 2025 (Open Access)*

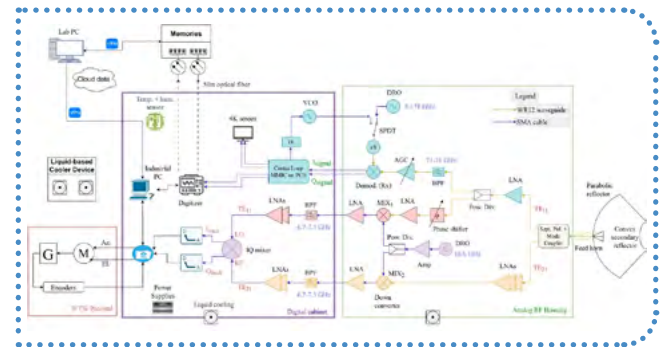

Concept of an in-orbit AI-system based on optical computing

• Felix Kübler, Mingwei Yang, Lennart Mannteuffel, Okan Akyüz, Janik Wolters & Enrico Stoll / *Published online: 02 May 2025 (Open Access)*

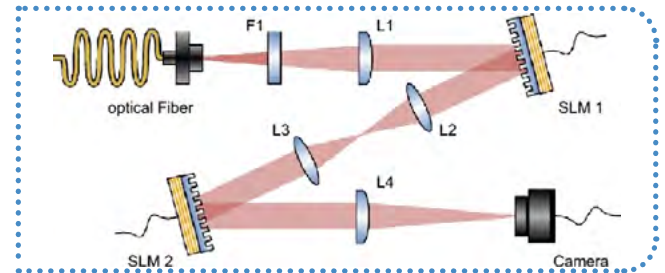

Developments toward ferrofluidic space technology as part of the technology demonstrator mission FINIX

• L. Mächtg, M. Schwerdhelm, M. Ferrer Garcia, Y. Ben Rajiba, M. Kob, M. Eisenbach, T. Friedrich, Y. Al Rifai, P. Heuser, J. Dietrich, N. Heinz, D. Bölke, S. Sütterlin, M. Ehresmann & G. Herdrich / *Published online: 17 May 2025 (Open Access)*



Feasible design of inflatable aeroshells for reentry capsules of sounding rockets in suborbital experiments

• Yasunori Nagata & Kazuhiko Yamada / *Published online: 19 May 2025*

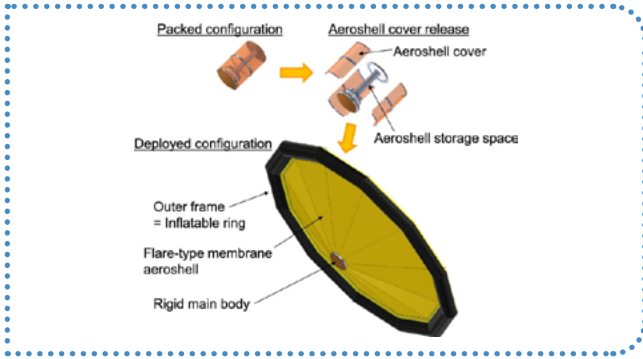

A light dust shield, including aerogel, for DISC instrument on board ESA's Comet Interceptor mission: numerical simulations and Ballistic Limit Equation

• A. M. Piccirillo, V. Della Corte, A. Rotundi, L. Inno, I. Bertini, F. Cozzolino, A. Ferone, S. Fiscale, A. Longobardo, S. Ferretti, E. Ammannito, C. Grappasonni, G. Sindoni, Z. Emerland, M. Sylvest, M. R. Patel, H. Ertel, M. Millinger & H. Rothkael / *Published online: 04 June 2025 (Open Access)*

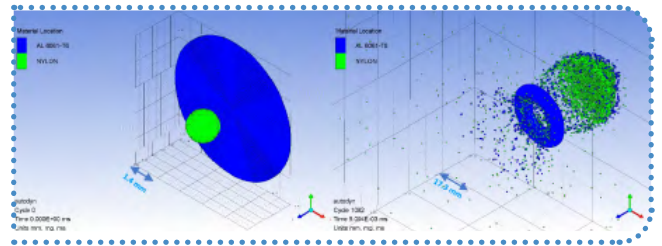

System design of the POQUITO PocketQube mission

• Vittorio Franzese, Konstantinos Kanavouras, Citlali Bruce Rosete, Spyridon Gouvalas, Niki Sajjad, Mohammadamin Alandihallaj, Alesia Herasimenka & Andreas Makoto Hein / *Published online: 26 May 2025*

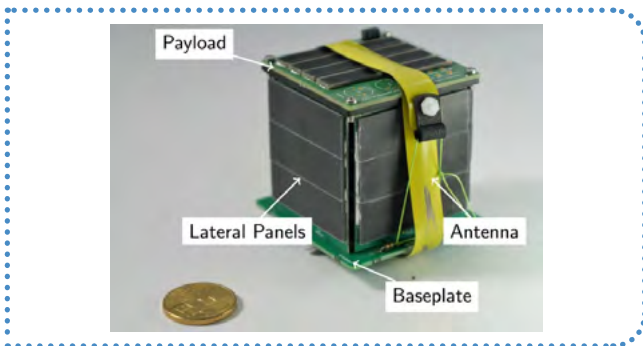

Assessment of methods and strategies for lunar dust mitigation experiments within a low-fidelity test environment

• Moritz Gewehr, Amran Al-Barwani, Daniel Bölke & Sabine Klinkner / *Published online: 11 June 2025 (Open Access)*



Comparison of SpaceX's Starship with winged heavy-lift launcher options for Europe

• Moritz Herberhold, Leonid Bussler, Martin Sippel & Jascha Wilken / *Published online: 28 May 2025 (Open Access)*

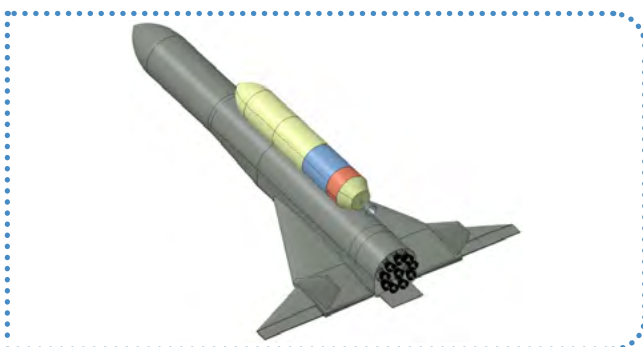

UPCOMING AEROSPACE EVENTS

2026

MARCH

- **7 – 14 March 2026** / The international IEEE Aerospace Conference, Big Sky, Montana USA <https://www.aero-conf.org/>

APRIL

- **7 – 9 April 2026** / 5th IAA Conference on Space Situational Awareness, Madrid, Spain
- **13 – 16 April 2026** / 41st Space Symposium, The Broadmoor, Colorado Springs, CO USA <https://www.spacesymposium.org/>
- **22 – 25 April 2026** / AERO Friedrichshafen EXPO, Friedrichshafen, Germany; <https://www.aero-expo.com/>
- **28 – 29 April 2026** / Aerospace Tech Week Europe, Munchen, Germany

MAY

- **5 – 7 May 2026** / The EuroGNC 2026, Madrid, Spain; <https://eurognc.ceas.org/>
- **13 – 15 May 2026** / 11th International Conference on Recent Advances in Air and Space Technologies (RAST 2026), Istanbul, Turkey
- **18 – 19 May 2026** / 5th Global Space Technology & Aerospace Congress, Munich, Germany
- **18 – 21 May 2026** / TRA BUDAPEST 2026 Regeneration in transport Budapest, Hungary <https://traconference.eu/index.html>
- **20 – 22 May 2026** / READ – Research & Education in Aircraft Design, Enna – Sicily, Italy <https://www.read2026.com/>
- **26 – 29 May 2026** / The 32nd AIAA/CEAS Aeroacoustics Conference (Aeroacoustics 2026), Brussels, Belgium; <https://www.aeroacoustics2026.eu/>

JUNE

- **10 – 14 June 2026** / ILA Berlin, <https://www.ila-berlin.de/en>
- **15 – 17 June 2026** / International Experts Summit on Aeronautics and Aerospace Engineering, Rome, Italy

- **16 – 18 June 2026** / The International Forum on Aeroelasticity and Structural Dynamics (IFASD) Goettingen, Germany

JULY

- **20 – 24 July 2026** / Farnborough International Airshow, Farnborough, UK <https://www.farnboroughairshow.com/>
- **20 – 23 July 2026** / The International Conference on Aeronautical and Aerospace Engineering (ICAAAE), Rome, Italy

AUGUST

- **1 – 9 August 2026** / The 46th COSPAR Scientific Assembly, Florence, Italy; <https://www.cospar-assembly.org/assembly.php>
- **14 – 15 August 2026** / International Conference on Aeronautical and Aerospace Engineering ICAAAE – Warsaw, Poland

SEPTEMBER

- **1 – 4 September** / 52nd European Rotorcraft Forum ERF 2026 – Amsterdam (The Netherlands) - <https://www.erf2026.org>
- **6 – 7 September 2026** / International Conference on Aerospace Sciences and Aviation Technology (ICASAT), Prague, Czech Republic
- **13 – 17 September 2026** / The 35th Congress of the International Council of the Aeronautical Sciences (ICAS 2026), Sydney, Australia; <https://icas2026.com/>
- **14 – 15 September 2026** / ISASSME 2026 – International Summit on Aerospace, Space Science and Mechanical Engineering, Berlin, Germany
- **16 – 17 September 2026** / ESA Industry Space Days at ESA/ESTEC. <https://isd.esa.int/>
- **20 – 21 September 2026** / International Conference on Aerospace and Aviation Engineering (ICAAE), Lisbon, Portugal

OCTOBER

- **1 – 2 October 2026** / ESA/CNES Space Cost Engineering Conference 2026, Noordwijk, The Netherlands
- **5-9 October 2026** / International Astronautical Congress (IAC) in Antalya, Türkiye.

UPCOMING AEROSPACE EVENTS

- **13 – 16 October 2026** / 6th SPACE PASSIVE COMPONENT DAYS - SPCD 2026, ESA/ESTEC, Noordwijk, The Netherlands <https://www.spcd.space/>

NOVEMBER

- **4 – 5 November 2026** / International Conference on Aerospace and Aviation Engineering" (ICAAE), New York, USA
- **18 – 20 November 2026** / Bahrain International Airshow, Bahrain

DECEMBER

- **9 – 10 December 2026** / GAD World (Global Airfinance Conference), Milano, Italy

2027

JANUARY

- **14 – 15 January 2027** / International Conference on Aeronautical and Aerospace Engineering (ICAAE), Zurich, Switzerland
- **26 – 27 January 2027** / 18th European Space Conference, Brussels, Belgium

FEBRUARY

- **8 – 10 February 2027** / Defense and Intelligence Space Conference 2027 (DISC27), Orlando, Florida, USA
- **15 – 16 February 2027** / International Conference on Aerospace and Aviation Engineering (ICAAE), Londyn, UK

MARCH

- **4 – 5 March 2027** / International Conference on Aeronautics and Astronautics (ICAA) - Barcelona, Spain
- **6 – 13 March 2027** / IEEE Aerospace Conference, Big Sky, Montana, USA
- **22 – 23 March 2027** / International Conference on Aeronautics and Aeroengineering (ICAA), Prague, Czech Republic

MAY

- **24 – 28 May 2027** / 5th HiSST International Conference on High-Speed Vehicle Science and Technology, Beijing, China

JUNE

- **14 – 20 June 2027** / 56th Paris Air Show, Paris-Le Bourget, France <https://www.siae.fr/en/>

SEPTEMBER

- **27 Sept – 1 October 2027** / International Astronautical Congress IAC 2027, Poznan, Poland

NOVEMBER

- **29 November - 2 December 2027** / 11th CEAS Aerospace Europe Conference, Augsburg, Germany
- **15 – 19 November 2027** / Dubai Airshow, Dubai, UAE <https://www.dubaiairshow.aero/en/>